

3.0	RIDUTTORE A VITE SENZA FINE SERIE K	K WORM GEARBOXES	SCHNECKENGETRIEBE K	
3.1	Caratteristiche	<i>Characteristics</i>	Merkmale	42
3.2	Designazione	<i>Designation</i>	Bezeichnung	43
3.3	Lubrificazione e posizioni di montaggio	<i>Lubrication and mounting position</i>	Schmierung und Einbaulage	43
3.4	Posizione morsettiera	<i>Terminal board positions</i>	Lage der Klemmenkaste	43
3.5	Dati tecnici	<i>Technical data</i>	Technische Daten	43
3.6	Momenti d'inerzia	<i>Moments of inertia</i>	Trägheitsmoment	54
3.7	Dimensioni	<i>Dimensions</i>	Abmessungen	56
3.8	Entrata supplementare	<i>Additional input</i>	Zusatzantrieb	59
3.9	Limitatore di coppia cavo passante	<i>Torque limiter with through hollow shaft</i>	Drehmomentbegrenzer mit durchgehender Hohlwelle	59
3.10	Accessori	<i>Accessories</i>	Zubehör	61
3.11	Lista parti di ricambio	<i>Spare parts list</i>	Ersatzteilliste	62

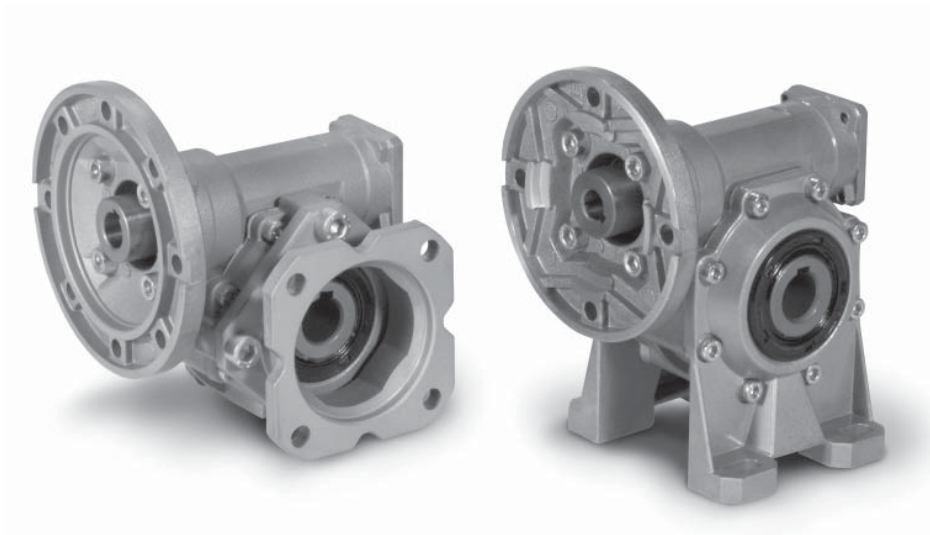

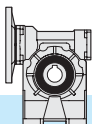

3.1 Caratteristiche

- I riduttori della serie a vite senza fine KC si presentano estremamente leggeri grazie alla forma compatta della carcassa in ghisa nelle grandezze 90, 110 e 130, in alluminio pressofuso per le grandezze 30, 40, 50, 63 e 75.
- La serie presenta una svariata possibilità di versioni, con e senza piedi, che la rendono più versatile nell'impiego in ogni tipologia di applicazione.
- La serie K è disponibile esclusivamente nella versione predisposta per attacco motore (PAM) e non con albero entrata maschio.
- La vite senza fine è in acciaio legato cementato-temprato ed è rettificata.
- La corona ha il mozzo in ghisa con riporto di fusione dell'anello in bronzo.
- Le carcasse in ghisa sono verniciate BLU RAL5010 mentre quelle in alluminio sono sabbiate.
- Viene fornito l'albero uscita cavo di serie ed esiste un'ampia disponibilità di accessori: seconda entrata, cuscinetti conici sulla corona, flangia uscita, albero lento con 1 o 2 sporgenze, limitatore di coppia con cavo passante, braccio di reazione, kit protezione albero cavo, kit protezione limitatore di coppia.

3.1 Characteristics

- *The KC worm gearboxes are extremely light thanks to the compact shape of the housing, which is in cast iron for sizes 90, 110 and 130, in die-cast aluminium for sizes 30, 40, 50, 63 and 75.*
- *This series features a wide range of versions, with and without feet, which makes it extremely versatile for utilization in various applications.*
- *The K series is available for motor mounting version (PAM) only and not with the male input shaft.*
- *The worm shaft is in case-and quench-hardened alloy steel and is ground.*
- *The worm wheel has a cast-iron hub with inserted cast bronze ring.*
- *The cast-iron housings are painted BLUE RAL5010 whereas the aluminium housings are sandblasted.*
- *The hollow output shaft is supplied as standard. A broad range of accessories is available: second input, tapered roller bearings on the worm wheel, output flange, single or double-extended output shaft, torque limiter with through hollow shaft, torque arm, hollow shaft protection kit, torque limiter protection kit.*

3.1 Merkmale

- Die Schneckengetriebe der Serie KC sind äußerst leicht dank der kompakten Form des Gehäuses. Das Gehäuse ist aus Gusseisen für Größen 90, 110 und 130, aus Druckgussaluminium für Größen 30, 40, 50, 63 und 75.
- Diese Serie ist in vielen Ausführungen, mit und ohne Füße erhältlich, was eine vielseitige Anwendbarkeit in unterschiedlichsten Applikationen ermöglicht.
- Die Serie K ist nur mit Motoranbau Version (IEC) und nicht mit einer Antriebswelle verfügbar.
- Die Schneckenwelle ist aus einsatzgehärtetem / abgeschrecktem und daraufhin geschliffenem Legierungsstahl.
- Das Schneckenrad besteht aus einer Nabe aus Gusseisen und einem aufgeschleuderten Gussbronze-Ring.
- Gehäuse aus Gusseisen werden mit BLAU RAL5010 lackiert, die Gehäuse aus Aluminium werden sandgestrahlt.
- Die Hohlwelle gehört zur serienmäßigen Ausstattung. Zahlreiches Zubehör ist lieferbar: zweiter Antrieb, Kegellager auf das Schneckenrad, Abtriebsflansch, Standard oder doppelseitig herausragende Abtriebswelle, Drehmomentbegrenzer mit durchgehender Hohlwelle, Drehmomentstütze, Schutzvorrichtung für Hohlwelle, Schutzvorrichtung für Drehmomentbegrenzer.

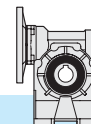

3.2 Designazione

3.2 Designation

3.2 Bezeichnung

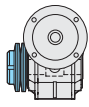
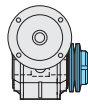
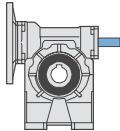
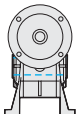
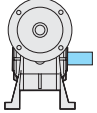
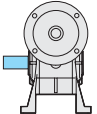
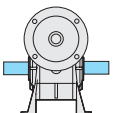
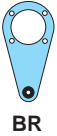
Riduttore Gearbox Getriebe	Tipo entrata Input type Antriebsart	Grandezza Size Größe	Versione Version Ausführung	Rapporto rid. Ratio Untersetzung	Predispos. att. mot. Motor coupling Motoranschluss	Posizione di mont. Mounting position Einbaulage	Limitatore di coppia. Torque limiter Drehmomentbegrenzer	Seconda entrata Additional input Zusatzantrieb	Albero uscita Output shaft Abtriebswelle	Braccio di reazione Torque arm Drehmomentstütze
K	C	50	F1S	10	P.A.M	B3	LD	SeA	H	BR
Riduttore a avite senza fine Wormgearbox Schneckengetriebe		30 40 50 63 75 90 110 130	A1-A2 B1-B2 V1-V2 P F1S-F2S F3S F1D-F2D F3D	7.5 10 15 20 25 30 40 50 65 80 100	56 63 71 80 90 100 112 132	B3 B6 B7 B8 V5 V6	 LS  LD	 SeA	 H  SD  SS  DD	 BR

Versioni

Versions

Ausführungen

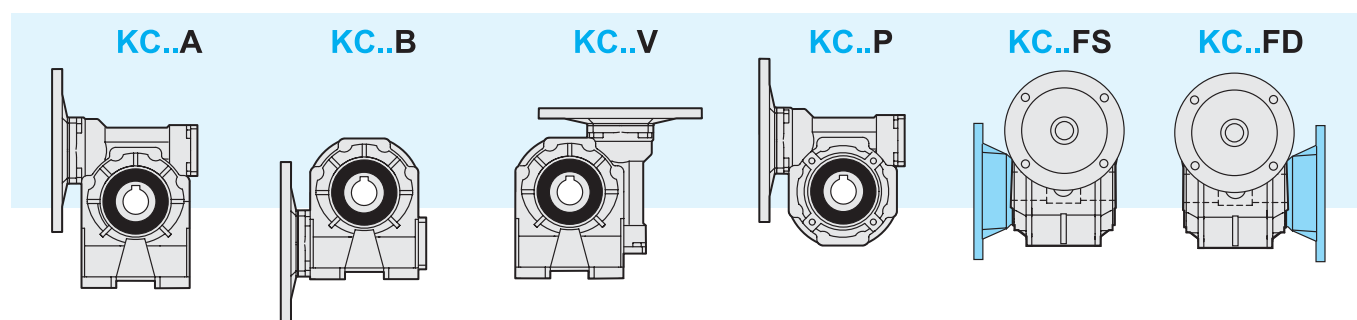

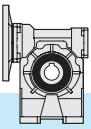

3.3 Lubrificazione

I riduttori a vite senza fine serie K, tranne la grandezza 130, sono forniti completi di lubrificante sintetico a base PAG con indice di viscosità ISO VG320. Si raccomanda di precisare sempre, in fase di ordine, la posizione di montaggio desiderata.

3.3 Lubrication

KC worm gearboxes, except for the size 130, are supplied with PAG synthetic lubricant featuring an ISO VG320 viscosity class. Always specify the required mounting position when ordering.

3.3 Schmierung

Schneckengetriebe der Serie KC, außer Größe 130, werden mit synthetischem Schmiermittel auf PAG Basis und Viskosität Index ISO VG320 geliefert. Im Auftrag bitte immer die gewünschte Einbaulage angeben.

Posizioni di montaggio

Mounting positions

Einbaulagen

F,P

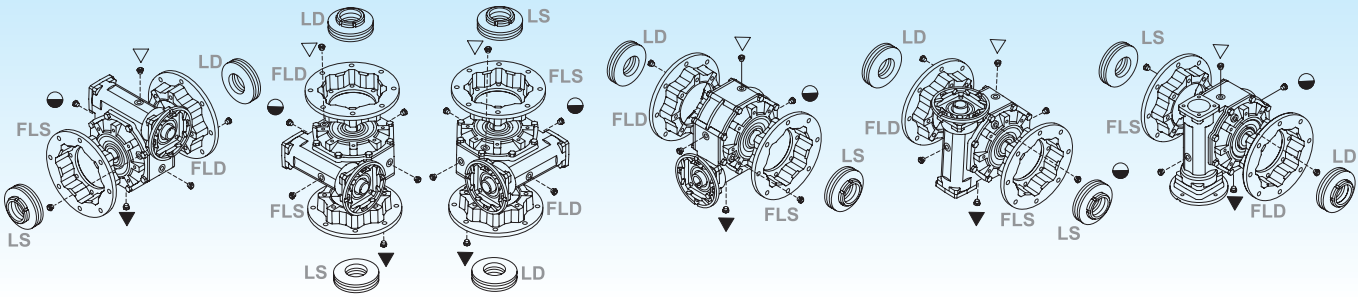

A

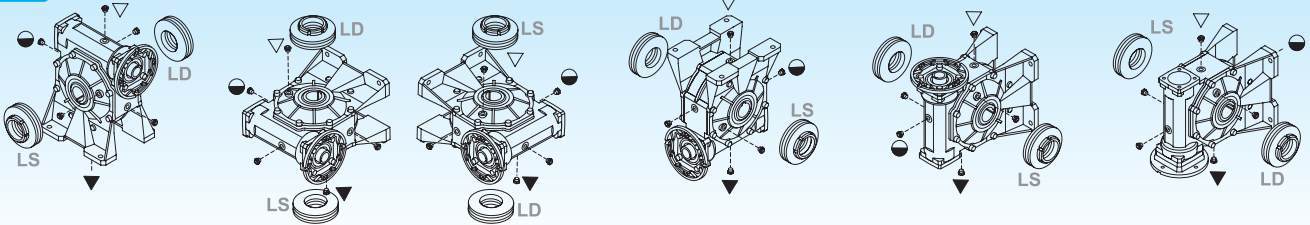

V

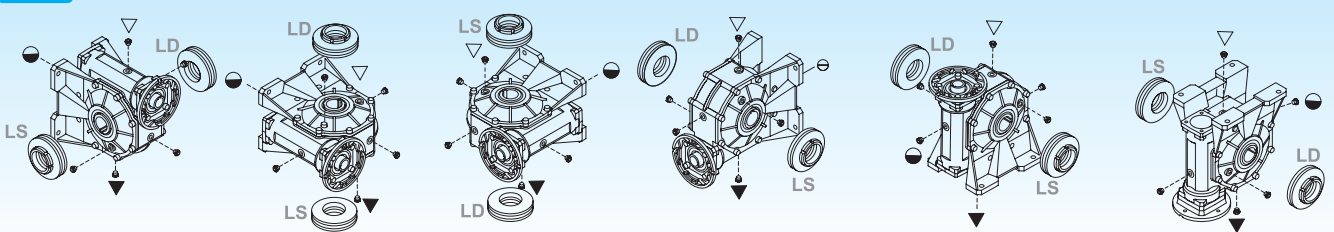

B

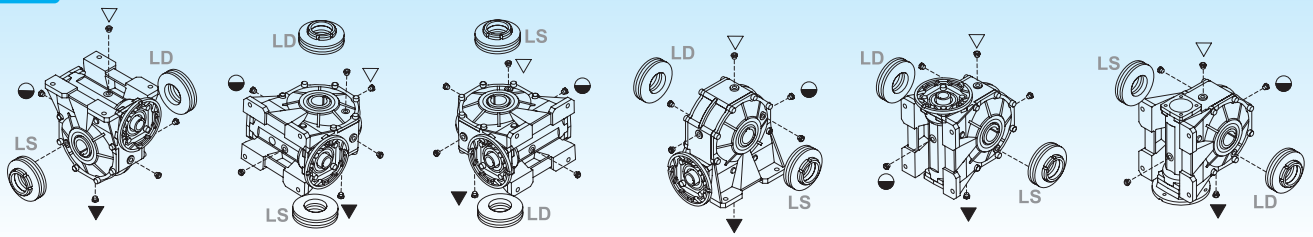

B3

B6

B7

B8

V5

V6

- ▽ Carico e sfiato / Filling and breather
Einfüll und Entlüftung
- Livello / Level / Ölstand
- ▼ Scarico / Drain / Ablass

Nei corpi in alluminio 30, 40, 50, 63, 75 è presente un solo tappo di riempimento olio.

Aluminium housings size 30, 40, 50, 63 and 75 have one filling plug only.

Gehäuse aus Aluminium Größe 30, 40, 50, 63 und 75 verfügen über nur eine Einfüllschraube.

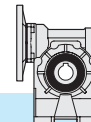

3.3 Lubrificazione

3.3 Lubrication

3.3 Schmierung

		Q.tà olio / Oil quantity / Schmiermittelmenge [lt]			
		Posizione di montaggio / Mounting position / Einbaulage			
		B3	B6 - B7	B8	V5 - V6
KC	30	0.015			
	40	0.040			
	50	0.080			
	63	0.160			
	75	0.260			
	90	1.1	0.9	1.3	1.2
	110	2.4	2	2.8	2.7
	130				

3.4 Posizione morsettiera

3.4 Terminal board position

3.4 Lage der Klemmenkaste

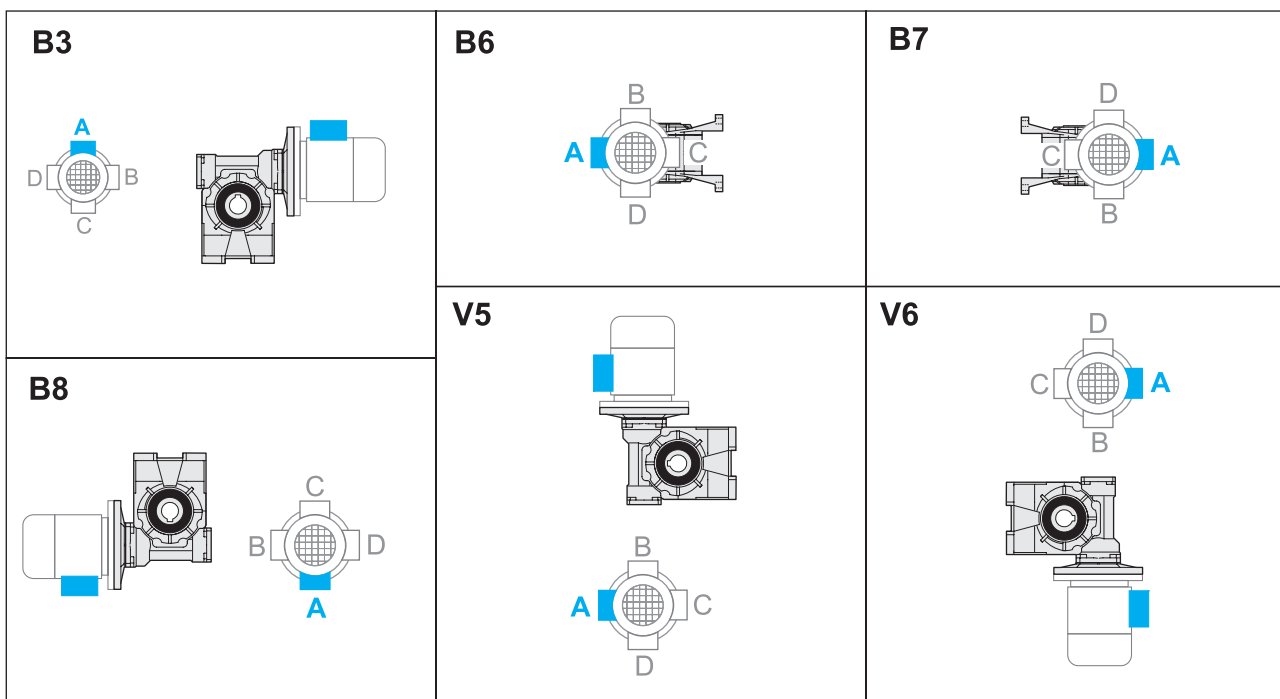

Specificare sempre in fase di ordinazione la posizione di montaggio e la forma costruttiva.

Specify the version and the mounting position when ordering.

Bei der Bestellung immer die gewünschte Montageposition und Bauform angeben.

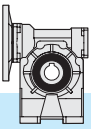

3.5 Dati tecnici

3.5 Technical data

3.5 Technische Daten

30	$n_1 = 2800$				KC				Input - IEC	
	i_n	n_2 [min ⁻¹]	Rd	P_{10}	T_2 [Nm]	P_1 [kW]	FS'	B5/B14		
	7.5	373	0.86	—	8	0.37	2.0	63	56	
10	280	0.84	11		0.37	1.5				
15	187	0.81	15		0.37	1.1				
20	140	0.76	13		0.25	1.2				
25	112	0.74	16		0.25	1.0				
30	93	0.71	13		0.18	1.0				
40	70	0.65	16		0.18	1.0				
50	56	0.62	14		0.13	1.1				
65	43	0.57	17		0.13	1.0				
80	35	0.54	13		0.09	1.0				
100	28	0.52	16	0.09	0.8	—				

1.2

30	$n_1 = 1400$				KC				Input - IEC	
	i_n	n_2 [min ⁻¹]	Rd	P_{10}	T_2 [Nm]	P_1 [kW]	FS'	B5/B14		
	7.5	187	0.84	0.40	9	0.22	2.2	63	56	
10	140	0.82	0.40	12	0.22	1.8				
15	93	0.77	0.30	17	0.22	1.3				
20	70	0.72	0.20	18	0.18	1.1				
25	56	0.69	0.20	21	0.18	1.0				
30	47	0.66	0.20	18	0.13	1.1				
40	35	0.59	0.20	21	0.13	1.0				
50	28	0.55	0.20	17	0.09	1.1				
65	22	0.51	0.10	20	0.09	1.0				
80	18	0.48	0.10	16	0.06	1.0				
100	14	0.45	0.10	18	0.06	0.8	—			

1.2

30	$n_1 = 900$				KC				Input - IEC	
	i_n	n_2 [min ⁻¹]	Rd	P_{10}	T_2 [Nm]	P_1 [kW]	FS'	B5/B14		
	7.5	120	0.82	—	9	0.13	2.9	63	56	
10	90	0.80	11		0.13	2.3				
15	60	0.75	15		0.13	1.6				
20	45	0.69	19		0.13	1.2				
25	36	0.66	23		0.13	1.1				
30	30	0.63	18		0.09	1.2				
40	23	0.55	21		0.09	1.1				
50	18	0.52	16		0.06	1.3				
65	14	0.48	20		0.06	1.1				
80	11	0.44	11		0.03	1.7				
100	9	0.42	13	0.03	1.1	—				

1.2

30	$n_1 = 500$				KC				Input - IEC	
	i_n	n_2 [min ⁻¹]	Rd	P_{10}	T_2 [Nm]	P_1 [kW]	FS'	B5/B14		
	7.5	67	0.80	—	—	—	—	63	56	
10	50	0.77	—		—	—				
15	33	0.72	—		—	—				
20	25	0.66	—		—	—				
25	20	0.62	—		—	—				
30	17	0.59	—		—	—				
40	13	0.51	—		—	—				
50	10	0.48	—		—	—				
65	8	0.43	—		—	—				
80	6	0.40	—		—	—				
100	5	0.38	—	—	—	—				

1.2

* **ATTENZIONE:** la coppia massima utilizzabile $[T_{2M}]$ deve essere calcolata utilizzando il fattore di servizio: $T_{2M} = T_2 \times FS'$

* **WARNING:** Maximum allowable torque $[T_{2M}]$ must be calculated using the following service factor: $T_{2M} = T_2 \times FS'$

* **ACHTUNG:** das max. anwendbare Drehmoment $[T_{2M}]$ muss mit folgendem Betriebsfaktor berechnet werden: $T_{2M} = T_2 \times FS'$

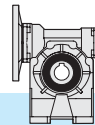

3.5 Dati tecnici

3.5 Technical data

3.5 Technische Daten

40	$n_1 = 2800$				KC					
	i_n	n_2 [min ⁻¹]	Rd	P_{t0}	T_2 [Nm]	P_1 [kW]	FS'	Input - IEC B5/B14		
									71	63
Kg 2.0	7.5	373	0.87	—	17	0.75	1.8	71	63	—
	10	280	0.86		22	0.75	1.4			
	15	187	0.82		32	0.75	1.0			
	20	140	0.80		30	0.55	1.0			
	25	112	0.76		24	0.37	1.1			
	30	93	0.73		28	0.37	1.3			
	40	70	0.70		24	0.25	1.4			
	50	56	0.65		28	0.25	1.1			
	65	43	0.61		24	0.18	1.2			
	80	35	0.58		21	0.13	1.3			
	100	28	0.55		24	0.13	1.0			

40	$n_1 = 1400$				KC					
	i_n	n_2 [min ⁻¹]	Rd	P_{t0}	T_2 [Nm]	P_1 [kW]	FS'	Input - IEC B5/B14		
									71	63
Kg 2.0	7.5	187	0.85	0.80	24	0.55	1.7	71	63	—
	10	140	0.83	0.70	31	0.55	1.3			
	15	93	0.79	0.50	30	0.37	1.4			
	20	70	0.76	0.50	38	0.37	1.0			
	25	56	0.72	0.40	31	0.25	1.1			
	30	47	0.68	0.40	35	0.25	1.2			
	40	35	0.64	0.30	38	0.22	1.0			
	50	28	0.59	0.30	36	0.18	1.1			
	65	22	0.54	0.20	31	0.13	1.1			
	80	18	0.52	0.20	31	0.11	1.1			
	100	14	0.49	0.20	30	0.09	0.9			

40	$n_1 = 900$				KC					
	i_n	n_2 [min ⁻¹]	Rd	P_{t0}	T_2 [Nm]	P_1 [kW]	FS'	Input - IEC B5/B14		
									71	63
Kg 2.0	7.5	120	0.83	—	25	0.37	2.0	71	63	—
	10	90	0.81		32	0.37	1.5			
	15	60	0.76		45	0.37	1.1			
	20	45	0.74		39	0.25	1.2			
	25	36	0.69		33	0.18	1.3			
	30	30	0.65		37	0.18	1.3			
	40	23	0.61		33	0.13	1.3			
	50	18	0.55		38	0.13	1.1			
	65	14	0.51		32	0.09	1.2			
	80	11	0.48		37	0.09	1.0			
	100	9	0.45		29	0.06	1.0			

40	$n_1 = 500$				KC					
	i_n	n_2 [min ⁻¹]	Rd	P_{t0}	T_2 [Nm]	P_1 [kW]	FS'	Input - IEC B5/B14		
									71	63
Kg 2.0	7.5	67	0.81	—	10	0.09	5.5	71	63	—
	10	50	0.79		14	0.09	4.4			
	15	33	0.73		19	0.09	3.1			
	20	25	0.70		24	0.09	2.3			
	25	20	0.65		28	0.09	1.7			
	30	17	0.61		31	0.09	1.8			
	40	13	0.57		39	0.09	1.3			
	50	10	0.51		44	0.09	1.2			
	65	8	0.46		52	0.09	0.9			
	80	6	0.44		61*	0.09	0.7*			
	100	5	0.41		71*	0.09	0.4*			

* **ATTENZIONE:** la coppia massima utilizzabile [T_{2M}] deve essere calcolata utilizzando il fattore di servizio: $T_{2M} = T_2 \times FS'$

* **WARNING:** Maximum allowable torque [T_{2M}] must be calculated using the following service factor: $T_{2M} = T_2 \times FS'$

* **ACHTUNG:** das max. anwendbare Drehmoment [T_{2M}] muss mit folgendem Betriebsfaktor berechnet werden: $T_{2M} = T_2 \times FS'$

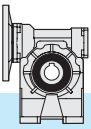

3.5 Dati tecnici

3.5 Technical data

3.5 Technische Daten

50	$n_1 = 2800$				KC					
	i_n	n_2 [min ⁻¹]	Rd	P_{t0}	T_2 [Nm]	P_1 [kW]	FS'	Input - IEC B5/B14		
								80	71	—
Kg 3.4	7.5	373	0.88	—	34	1.5	1.5	80	71	—
	10	280	0.86		44	1.5	1.2			
	15	187	0.84		47	1.1	1.2			
	20	140	0.81		42	0.75	1.4			
	25	112	0.78		50	0.75	1.0			
	30	93	0.75		42	0.55	1.3			
	40	70	0.72		54	0.55	1.0			
	50	56	0.68		43	0.37	1.3			
	65	43	0.64		53	0.37	1.0			
	80	35	0.61		41	0.25	1.2			
100	28	0.58	35	0.18	1.3	—	63			

50	$n_1 = 1400$				KC					
	i_n	n_2 [min ⁻¹]	Rd	P_{t0}	T_2 [Nm]	P_1 [kW]	FS'	Input - IEC B5/B14		
								80	71	—
Kg 3.4	7.5	187	0.86	1.2	40	0.9	1.8	80	71	—
	10	140	0.84	1.0	52	0.9	1.4			
	15	93	0.80	0.80	74	0.9	1.0			
	20	70	0.78	0.70	58	0.55	1.3			
	25	56	0.74	0.60	47	0.37	1.4			
	30	47	0.71	0.60	53	0.37	1.2			
	40	35	0.67	0.50	68	0.37	1.0			
	50	28	0.62	0.40	53	0.25	1.3			
	65	22	0.58	0.40	64	0.25	1.0			
	80	18	0.54	0.40	53	0.18	1.1			
100	14	0.51	0.30	45	0.13	1.2	—	63		

50	$n_1 = 900$				KC					
	i_n	n_2 [min ⁻¹]	Rd	P_{t0}	T_2 [Nm]	P_1 [kW]	FS'	Input - IEC B5/B14		
								80	71	—
Kg 3.4	7.5	120	0.84	—	50	0.75	1.6	80	71	—
	10	90	0.82		66	0.75	1.3			
	15	60	0.78		68	0.55	1.3			
	20	45	0.75		59	0.37	1.5			
	25	36	0.71		70	0.37	1.1			
	30	30	0.67		79	0.37	1.0			
	40	23	0.63		67	0.25	1.1			
	50	18	0.59		78	0.25	1.0			
	65	14	0.54		67	0.18	1.1			
	80	11	0.51		56	0.13	1.2			
100	9	0.47	45	0.09	1.3	—	63			

50	$n_1 = 500$				KC					
	i_n	n_2 [min ⁻¹]	Rd	P_{t0}	T_2 [Nm]	P_1 [kW]	FS'	Input - IEC B5/B14		
								80	71	—
Kg 3.4	7.5	67	0.82	—	21	0.18	4.7	80	71	—
	10	50	0.80		28	0.18	3.8			
	15	33	0.75		39	0.18	2.7			
	20	25	0.72		50	0.18	2.1			
	25	20	0.68		58	0.18	1.5			
	30	17	0.63		65	0.18	1.5			
	40	13	0.59		81	0.18	1.2			
	50	10	0.54		93	0.18	1.0			
	65	8	0.50		56	0.09	1.5			
	80	6	0.46		63	0.09	1.2			
100	5	0.43	74	0.09	0.8	—	63			

* **ATTENZIONE:** la coppia massima utilizzabile $[T_{2M}]$ deve essere calcolata utilizzando il fattore di servizio: $T_{2M} = T_2 \times FS'$

* **WARNING:** Maximum allowable torque $[T_{2M}]$ must be calculated using the following service factor: $T_{2M} = T_2 \times FS'$

* **ACHTUNG:** das max. anwendbare Drehmoment $[T_{2M}]$ muss mit folgendem Betriebsfaktor berechnet werden: $T_{2M} = T_2 \times FS'$

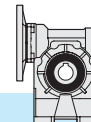

3.5 Dati tecnici

3.5 Technical data

3.5 Technische Daten

63	$n_1 = 2800$				KC					
	i_n	n_2 [min ⁻¹]	Rd	P_{t0}	T_2 [Nm]	P_1 [kW]	FS'	Input - IEC B5/B14		
								90	80	—
Kg 5.7	7.5	373	0.88	—	68	3	1.3			
	10	280	0.87		89	3	1.1			
	15	187	0.84		95	2.2	1.0			
	20	140	0.83		85	1.5	1.3			
	25	112	0.81		76	1.1	1.2			
	30	93	0.77		87	1.1	1.3			
	40	70	0.74		111	1.1	1.1			
	50	56	0.70		90	0.75	1.1			
	65	43	0.67		81	0.55	1.2			
	80	35	0.64		65	0.37	1.4			
100	28	0.60	75	0.37	1.1					

63	$n_1 = 1400$				KC					
	i_n	n_2 [min ⁻¹]	Rd	P_{t0}	T_2 [Nm]	P_1 [kW]	FS'	Input - IEC B5/B14		
								90	80	—
Kg 5.7	7.5	187	0.87	1.8	80	1.8	1.5			
	10	140	0.85	1.6	105	1.8	1.2			
	15	93	0.81	1.2	125	1.5	1.1			
	20	70	0.80	1.2	120	1.1	1.2			
	25	56	0.77	1.0	118	0.9	1.0			
	30	47	0.73	0.90	134	0.9	1.1			
	40	35	0.69	0.80	142	0.75	1.1			
	50	28	0.65	0.70	122	0.55	1.0			
	65	22	0.61	0.60	100	0.37	1.2			
	80	18	0.58	0.60	79	0.25	1.4			
100	14	0.53	0.50	91	0.25	1.1				

63	$n_1 = 900$				KC					
	i_n	n_2 [min ⁻¹]	Rd	P_{t0}	T_2 [Nm]	P_1 [kW]	FS'	Input - IEC B5/B14		
								90	80	—
Kg 5.7	7.5	120	0.85	—	102	1.5	1.4			
	10	90	0.83		133	1.5	1.1			
	15	60	0.79		139	1.1	1.1			
	20	45	0.77		123	0.75	1.4			
	25	36	0.74		109	0.55	1.3			
	30	30	0.70		122	0.55	1.3			
	40	23	0.66		154	0.55	1.1			
	50	18	0.61		120	0.37	1.2			
	65	14	0.57		98	0.25	1.4			
	80	11	0.54		115	0.25	1.1			
100	9	0.50	95	0.18	1.2					

63	$n_1 = 500$				KC					
	i_n	n_2 [min ⁻¹]	Rd	P_{t0}	T_2 [Nm]	P_1 [kW]	FS'	Input - IEC B5/B14		
								90	80	—
Kg 5.7	7.5	67	0.83	—	30	0.25	5.9			
	10	50	0.81		39	0.25	4.7			
	15	33	0.76		55	0.25	3.4			
	20	25	0.74		71	0.25	2.8			
	25	20	0.71		85	0.25	1.9			
	30	17	0.65		94	0.25	2.1			
	40	13	0.62		118	0.25	1.7			
	50	10	0.56		135	0.25	1.2			
	65	8	0.52		163	0.25	1.0			
	80	6	0.50		137	0.18	1.1			
100	5	0.45	77	0.09	1.6					

* **ATTENZIONE:** la coppia massima utilizzabile $[T_{2M}]$ deve essere calcolata utilizzando il fattore di servizio: $T_{2M} = T_2 \times FS'$

* **WARNING:** Maximum allowable torque $[T_{2M}]$ must be calculated using the following service factor: $T_{2M} = T_2 \times FS'$

* **ACHTUNG:** das max. anwendbare Drehmoment $[T_{2M}]$ muss mit folgendem Betriebsfaktor berechnet werden: $T_{2M} = T_2 \times FS'$

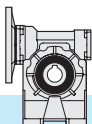

3.5 Dati tecnici

3.5 Technical data

3.5 Technische Daten

75	n₁ = 2800				KC						
	i _n	n ₂ [min ⁻¹]	Rd	P _{t0}	T ₂ [Nm]	P ₁ [kW]	FS'	Input - IEC B5/B14			
								112	90	80	
 9.5	7.5	373	0.89	—	125	5.5	1.0	112	100	90	—
	10	280	0.88		120	4	1.2				
	15	187	0.85		131	3	1.2				
	20	140	0.84		171	3	1.0				
	25	112	0.82		154	2.2	1.0				
	30	93	0.78		120	1.5	1.4				
	40	70	0.75		154	1.5	1.2				
	50	56	0.73		136	1.1	1.2				
	65	43	0.69		114	0.75	1.4				
	80	35	0.66		135	0.75	1.1				
100	28	0.62	159	0.75	0.8	—	80				

75	n₁ = 1400				KC						
	i _n	n ₂ [min ⁻¹]	Rd	P _{t0}	T ₂ [Nm]	P ₁ [kW]	FS'	Input - IEC B5/B14			
								112	90	80	
 9.5	7.5	187	0.87	2.5	178	4	1.0	112	100	90	—
	10	140	0.86	2.3	176	3	1.1				
	15	93	0.83	1.9	187	2.2	1.1				
	20	70	0.81	1.7	199	1.8	1.1				
	25	56	0.78	1.5	200	1.5	1.0				
	30	47	0.74	1.2	167	1.1	1.3				
	40	35	0.71	1.1	213	1.1	1.1				
	50	28	0.67	1.0	206	0.9	1.0				
	65	22	0.63	0.90	154	0.55	1.3				
	80	18	0.60	0.80	180	0.55	1.0				
100	14	0.56	0.70	210	0.55	0.8	—	80			

75	n₁ = 900				KC						
	i _n	n ₂ [min ⁻¹]	Rd	P _{t0}	T ₂ [Nm]	P ₁ [kW]	FS'	Input - IEC B5/B14			
								112	90	80	
 9.5	7.5	120	0.86	—	205	3	1.0	112	100	90	—
	10	90	0.84		197	2.2	1.2				
	15	60	0.81		231	1.8	1.0				
	20	45	0.78		250	1.5	1.1				
	25	36	0.76		221	1.1	1.1				
	30	30	0.71		249	1.1	1.0				
	40	23	0.67		214	0.75	1.3				
	50	18	0.64		186	0.55	1.3				
	65	14	0.59		151	0.37	1.5				
	80	11	0.56		177	0.37	1.2				
100	9	0.52	203	0.37	0.9	—	80				

75	n₁ = 500				KC						
	i _n	n ₂ [min ⁻¹]	Rd	P _{t0}	T ₂ [Nm]	P ₁ [kW]	FS'	Input - IEC B5/B14			
								112	90	80	
 9.5	7.5	67	0.84	—	90	0.75	2.9	112	100	90	—
	10	50	0.82		118	0.75	2.4				
	15	33	0.78		167	0.75	1.7				
	20	25	0.75		216	0.75	1.5				
	25	20	0.72		260	0.75	1.1				
	30	17	0.67		288	0.75	1.1				
	40	13	0.63		265	0.55	1.2				
	50	10	0.59		210	0.37	1.3				
	65	8	0.55		251	0.37	1.0				
	80	6	0.52		197	0.25	1.2				
100	5	0.47	161	0.18	1.3	—	80				

* **ATTENZIONE:** la coppia massima utilizzabile [T_{2M}] deve essere calcolata utilizzando il fattore di servizio: T_{2M} = T₂ x FS'

* **WARNING:** Maximum allowable torque [T_{2M}] must be calculated using the following service factor : T_{2M} = T₂ x FS'

* **ACHTUNG:** das max. anwendbare Drehmoment [T_{2M}] muss mit folgendem Betriebsfaktor berechnet werden: T_{2M} = T₂ x FS'

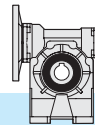



3.5 Dati tecnici

3.5 Technical data

3.5 Technische Daten

90	$n_1 = 2800$				KC						
	i_n	n_2 [min ⁻¹]	Rd	P_{t0}	T_2 [Nm]	P_1 [kW]	FS'	Input - IEC B5/B14			
				—				112 100	90	—	
											
16.4											
7.5	373	0.89	171		7.5	1.2					
10	280	0.88	165		5.5	1.3					
15	187	0.86	241		5.5	1.0					
20	140	0.84	230		4	1.2					
25	112	0.83	212		3	1.2					
30	93	0.79	243		3	1.1					
40	70	0.77	230		2.2	1.3					
50	56	0.74	278		2.2	1.0					
65	43	0.71	235		1.5	1.1					
80	35	0.68	205	1.1	1.2						
100	28	0.64	163	0.75	1.3						
						—			80		

90	$n_1 = 1400$				KC						
	i_n	n_2 [min ⁻¹]	Rd	P_{t0}	T_2 [Nm]	P_1 [kW]	FS'	Input - IEC B5/B14			
				—				112 100	90	—	
											
16.4											
7.5	187	0.88	247		5.5	1.2					
10	140	0.86	236		4	1.3					
15	93	0.84	256		3	1.2					
20	70	0.82	334		3	1.1					
25	56	0.80	299		2.2	1.1					
30	47	0.76	340		2.2	1.0					
40	35	0.72	355		1.8	1.1					
50	28	0.69	353		1.5	1.0					
65	22	0.65	317		1.1	1.0					
80	18	0.63	309	0.9	1.0						
100	14	0.58	217	0.55	1.2						
						—			80		

90	$n_1 = 900$				KC						
	i_n	n_2 [min ⁻¹]	Rd	P_{t0}	T_2 [Nm]	P_1 [kW]	FS'	Input - IEC B5/B14			
				—				112 100	90	—	
											
16.4											
7.5	120	0.86	206		3	1.7					
10	90	0.85	270		3	1.3					
15	60	0.82	286		2.2	1.3					
20	45	0.79	371		2.2	1.1					
25	36	0.77	369		1.8	1.0					
30	30	0.73	416		1.8	1.0					
40	23	0.69	440		1.5	1.0					
50	18	0.66	384		1.1	1.0					
65	14	0.62	319		0.75	1.1					
80	11	0.59	274	0.55	1.2						
100	9	0.54	313	0.55	1.0						
						—			80		

90	$n_1 = 500$				KC						
	i_n	n_2 [min ⁻¹]	Rd	P_{t0}	T_2 [Nm]	P_1 [kW]	FS'	Input - IEC B5/B14			
				—				112 100	90	—	
											
16.4											
7.5	67	0.84	91		0.75	4.7					
10	50	0.83	118		0.75	3.7					
15	33	0.79	169		0.75	2.7					
20	25	0.76	219		0.75	2.3					
25	20	0.74	265		0.75	1.7					
30	17	0.68	294		0.75	1.6					
40	13	0.65	371		0.75	1.4					
50	10	0.61	439		0.75	1.1					
65	8	0.57	388		0.55	1.1					
80	6	0.54	305	0.37	1.3						
100	5	0.49	344	0.37	1.0						
						—			80		

* **ATTENZIONE:** la coppia massima utilizzabile $[T_{2M}]$ deve essere calcolata utilizzando il fattore di servizio: $T_{2M} = T_2 \times FS'$

* **WARNING:** Maximum allowable torque $[T_{2M}]$ must be calculated using the following service factor: $T_{2M} = T_2 \times FS'$

* **ACHTUNG:** das max. anwendbare Drehmoment $[T_{2M}]$ muss mit folgendem Betriebsfaktor berechnet werden: $T_{2M} = T_2 \times FS'$

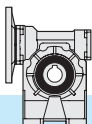

3.5 Dati tecnici

3.5 Technical data

3.5 Technische Daten

110	$n_1 = 2800$				KC					
	i_n	n_2 [min ⁻¹]	Rd	P_{t0}	T_2 [Nm]	P_1 [kW]	FS'	Input - IEC B5/B14		
									132	112 100
 31.5	7.5	373	0.89	—	343	15	1.0	132	112 100	—
	10	280	0.88		332	11	1.1			
	15	187	0.86		331	7.5	1.2			
	20	140	0.85		435	7.5	1.1			
	25	112	0.84		393	5.5	1.1			
	30	93	0.80		450	5.5	1.0			
	40	70	0.78		424	4	1.2			
	50	56	0.76		388	3	1.2			
	65	43	0.73		354	2.2	1.2			
	80	35	0.70		287	1.5	1.4			
100	28	0.66	339	1.5	1.1					
								—		90
								—		—
								—		90

110	$n_1 = 1400$				KC					
	i_n	n_2 [min ⁻¹]	Rd	P_{t0}	T_2 [Nm]	P_1 [kW]	FS'	Input - IEC B5/B14		
									132	112 100
 31.5	7.5	187	0.88	4.3	415	9.2	1.2	132	112 100	—
	10	140	0.87	4.0	446	7.5	1.1			
	15	93	0.84	3.2	475	5.5	1.1			
	20	70	0.83	3.0	623	5.5	1.0			
	25	56	0.81	2.7	554	4	1.0			
	30	47	0.77	2.2	472	3	1.3			
	40	35	0.74	2.0	606	3	1.1			
	50	28	0.72	1.8	538	2.2	1.1			
	65	22	0.68	1.6	451	1.5	1.2			
	80	18	0.65	1.5	390	1.1	1.3			
100	14	0.61	1.3	458	1.1	1.0				
								—		90
								—		—
								—		90

110	$n_1 = 900$				KC					
	i_n	n_2 [min ⁻¹]	Rd	P_{t0}	T_2 [Nm]	P_1 [kW]	FS'	Input - IEC B5/B14		
									132	112 100
 31.5	7.5	120	0.87	—	381	5.5	1.5	132	112 100	—
	10	90	0.86		500	5.5	1.2			
	15	60	0.83		526	4	1.2			
	20	45	0.81		685	4	1.1			
	25	36	0.79		628	3	1.1			
	30	30	0.74		520	2.2	1.3			
	40	23	0.71		664	2.2	1.1			
	50	18	0.68		653	1.8	1.1			
	65	14	0.64		487	1.1	1.2			
	80	11	0.61		570	1.1	1.0			
100	9	0.57	450	0.75	1.1					
								—		90
								—		—
								—		90

110	$n_1 = 500$				KC					
	i_n	n_2 [min ⁻¹]	Rd	P_{t0}	T_2 [Nm]	P_1 [kW]	FS'	Input - IEC B5/B14		
									132	112 100
 31.5	7.5	67	0.85	—	183	1.5	3.9	132	112 100	—
	10	50	0.84		240	1.5	3.1			
	15	33	0.80		344	1.5	2.3			
	20	25	0.78		446	1.5	1.9			
	25	20	0.76		542	1.5	1.5			
	30	17	0.70		603	1.5	1.4			
	40	13	0.67		765	1.5	1.2			
	50	10	0.64		671	1.1	1.2			
	65	8	0.59		553	0.75	1.3			
	80	6	0.56		643	0.75	1.0			
100	5	0.52	542	0.55	1.1					
								—		90
								—		—
								—		90

* **ATTENZIONE:** la coppia massima utilizzabile $[T_{2M}]$ deve essere calcolata utilizzando il fattore di servizio: $T_{2M} = T_2 \times FS'$

* **WARNING:** Maximum allowable torque $[T_{2M}]$ must be calculated using the following service factor: $T_{2M} = T_2 \times FS'$

* **ACHTUNG:** das max. anwendbare Drehmoment $[T_{2M}]$ muss mit folgendem Betriebsfaktor berechnet werden: $T_{2M} = T_2 \times FS'$

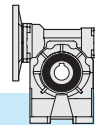

3.5 Dati tecnici

3.5 Technical data

3.5 Technische Daten

130	$n_1 = 2800$				KC				
	i_n	n_2 [min ⁻¹]	Rd	P_{t0}	T_2 [Nm]	P_1 [kW]	FS'	Input - IEC B5/B14	
	7.5	373	0.90	—	345	15	1.5	132	112 100
10	280	0.89	455		15	1.2			
15	187	0.87	490		11	1.3			
20	140	0.86	645		11	1.1			
25	112	0.85	667		9.2	1.1			
30	93	0.81	622		7.5	1.2			
40	70	0.80	819		7.5	1.0			
50	56	0.78	732		5.5	1.0			
65	43	0.75	499		3	1.3	—	90	
80	35	0.73	598		3	1.1			
100	28	0.70	525		2.2	1.1			

130	$n_1 = 1400$				KC				
	i_n	n_2 [min ⁻¹]	Rd	P_{t0}	T_2 [Nm]	P_1 [kW]	FS'	Input - IEC B5/B14	
	7.5	187	0.89	6.0	418	9.2	1.8	132	112 100
10	140	0.88	5.5	552	9.2	1.4			
15	93	0.85	4.4	803	9.2	1.1			
20	70	0.84	4.1	860	7.5	1.1			
25	56	0.83	3.9	778	5.5	1.2			
30	47	0.79	3.2	883	5.5	1.1			
40	35	0.76	2.8	829	4	1.3			
50	28	0.74	2.6	757	3	1.3	—	90	
65	22	0.71	2.3	678	2.2	1.2			
80	18	0.68	2.1	649	1.8	1.2			
100	14	0.64	1.8	655	1.5	1.1			

130	$n_1 = 900$				KC				
	i_n	n_2 [min ⁻¹]	Rd	P_{t0}	T_2 [Nm]	P_1 [kW]	FS'	Input - IEC B5/B14	
	7.5	120	0.88	—	385	5.5	2.3	132	112 100
10	90	0.87	508		5.5	1.8			
15	60	0.84	735		5.5	1.4			
20	45	0.82	957		5.5	1.2			
25	36	0.81	860		4	1.3			
30	30	0.76	968		4	1.2			
40	23	0.73	930		3	1.3			
50	18	0.70	817		2.2	1.3	—	90	
65	14	0.67	832		1.8	1.1			
80	11	0.64	815		1.5	1.1			
100	9	0.60	700		1.10	1.2			

130	$n_1 = 500$				KC				
	i_n	n_2 [min ⁻¹]	Rd	P_{t0}	T_2 [Nm]	P_1 [kW]	FS'	Input - IEC B5/B14	
	7.5	67	0.86	—	228	1.85	4.9	132	112 100
10	50	0.84	297		1.85	3.7			
15	33	0.81	429		1.85	2.9			
20	25	0.79	558		1.85	2.5			
25	20	0.78	689		1.85	1.8			
30	17	0.72	763		1.85	1.7			
40	13	0.69	975		1.85	1.5			
50	10	0.66	1166		1.85	1.1	—	90	
65	8	0.63	860		1.10	1.3			
80	6	0.59	992		1.10	1.1			
100	5	0.55	788		0.75	1.2			

* **ATTENZIONE:** la coppia massima utilizzabile $[T_{2M}]$ deve essere calcolata utilizzando il fattore di servizio: $T_{2M} = T_2 \times FS'$

* **WARNING:** Maximum allowable torque $[T_{2M}]$ must be calculated using the following service factor: $T_{2M} = T_2 \times FS'$

* **ACHTUNG:** das max. anwendbare Drehmoment $[T_{2M}]$ muss mit folgendem Betriebsfaktor berechnet werden: $T_{2M} = T_2 \times FS'$

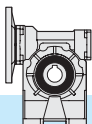



3.6 **Momenti d' inerzia [Kg.cm²]**
(riferiti all'albero veloce in entrata)

3.6 **Moments of inertia [Kg.cm²]**
(referred to input shaft)

3.6 **Trägheitsmoment [Kg.cm²]**
(bez. Antriebswelle)

K30	i_n	 KC B5 - B14	
		IEC 56	IEC 63
		7.5	0.112
10	0.103	0.100	
15	0.097	0.094	
20	0.095	0.092	
25	0.094	0.091	
30	0.093	0.090	
40	0.093	0.090	
50	0.092	0.089	
65	0.079	-	
80	0.079	-	
100	0.078	-	

K40	i_n	 KC B5 - B14		
		IEC 56	IEC 63	IEC 71
		7.5	-	0.321
10	-	0.272	0.347	
15	-	0.266	0.340	
20	-	0.263	0.338	
25	-	0.262	0.337	
30	-	0.262	0.337	
40	-	0.261	-	
50	-	0.261	-	
65	0.182	0.261	-	
80	0.182	0.261	-	
100	0.182	0.261	-	

K50	i_n	 KC B5 - B14		
		IEC 63	IEC 71	IEC 80
		7.5	-	0.684
10	-	0.602	0.853	
15	-	0.543	0.794	
20	-	0.523	0.774	
25	-	0.513	0.764	
30	-	0.508	0.759	
40	-	0.503	-	
50	-	0.501	-	
65	0.311	0.499	-	
80	0.310	0.498	-	
100	0.309	0.498	-	

K63	i_n	 KC B5 - B14		
		IEC 71	IEC 80	IEC 63
		7.5	-	1.949
10	-	1.744	2.063	
15	-	1.597	1.916	
20	-	1.545	1.864	
25	-	1.514	1.833	
30	-	1.508	1.828	
40	-	1.495	-	
50	-	1.488	-	
65	0.955	1.484	-	
80	0.953	1.482	-	
100	0.952	1.481	-	

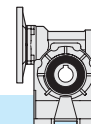



3.6 **Momenti d' inerzia** [Kg.cm²]
(riferiti all'albero veloce in entrata)

3.6 **Moments of inertia** [Kg.cm²]
(referred to input shaft)

3.6 **Trägheitsmoment** [Kg.cm²]
(bez. Antriebswelle)

	i_n	 KC		
		B5 - B14		
		IEC 80	IEC 90	IEC 100-112
K75	7.5	-	3.712	4.462
	10	-	3.234	3.984
	15	-	2.893	3.643
	20	-	2.774	3.523
	25	-	2.709	3.458
	30	-	2.689	3.438
	40	-	2.659	-
	50	-	2.642	-
	65	1.569	2.633	-
	80	1.565	2.629	-
	100	1.562	2.626	-

	i_n	 KC		
		B5 - B14		
		IEC 80	IEC 90	IEC 100-112
K90	7.5	-	6.898	7.671
	10	-	5.875	6.648
	15	-	5.144	5.917
	20	-	3.398	5.661
	25	-	3.256	5.520
	30	-	3.215	5.479
	40	-	3.151	-
	50	-	3.115	-
	65	2.024	3.096	-
	80	2.014	3.087	-
	100	2.008	3.080	-

	i_n	 KC		
		B5 - B14		
		IEC 90	IEC 100-112	IEC 132
K110	7.5	-	17.980	20.038
	10	-	15.119	17.177
	15	-	13.076	15.134
	20	-	8.367	14.418
	25	-	7.969	14.020
	30	-	11.850	13.908
	40	-	7.677	-
	50	-	7.578	-
	65	5.592	7.510	-
	80	5.570	7.489	-
	100	5.555	7.474	-

	i_n	 KC		
		B5 - B14		
		IEC 90	IEC 100-112	IEC 132
K130	7.5	-	40.70	42.78
	10	-	32.96	35.04
	15	-	27.43	29.51
	20	-	16.68	27.58
	25	-	15.52	26.42
	30	-	24.12	26.20
	40	-	14.81	25.71
	50	-	12.57	-
	65	10.46	14.35	-
	80	10.41	14.30	-
	100	10.37	14.26	-

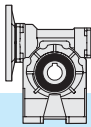

3.7 Dimensioni

3.7 Dimensions

3.7 Abmessungen

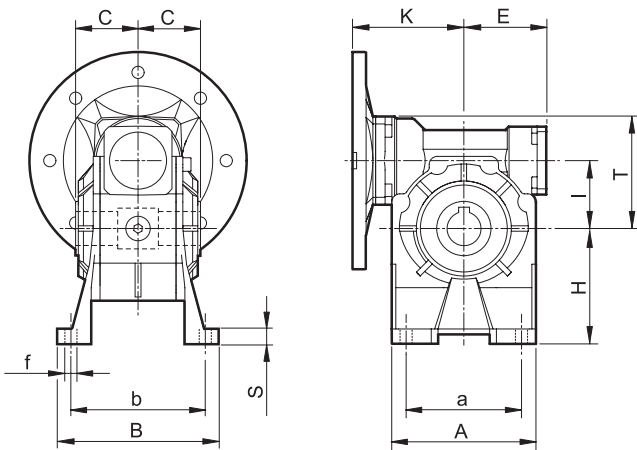

KC..A

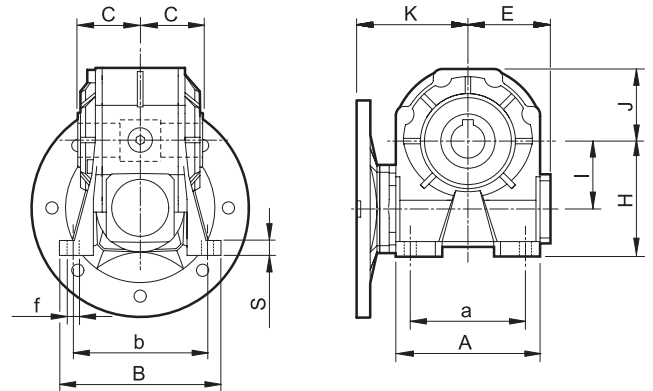

KC..B

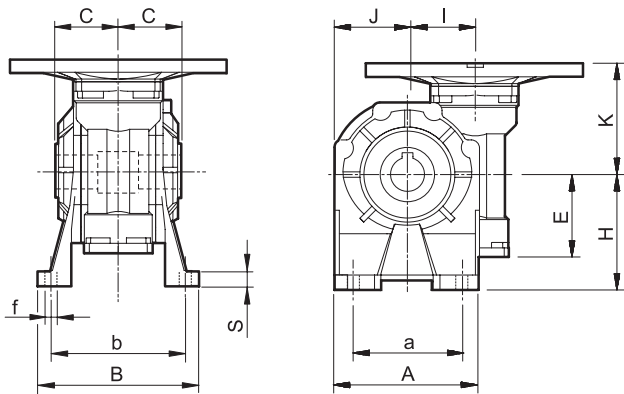

KC..V

	30	40	50	63	75	90	110	130
b2	5	6 (6)	8 (8)	8	8 (8)	10	12	14
C	31.5	39	46	56	60	70	77.5	85
D2 H7	14	18 (19)	25 (24)	25	28 (30)	35	42	45 (48)
E	41	51	60	71	85	103	127.5	147.5
G h8	55	60	70	80	95	110	130	180
I	31.5	40	50	63	75	90	110	130
J	37.5	43.5	53.5	64	78	100	122	145.5
K	57	75	82	97	114	122	153	173
M	M6x8	M6x10	M8x10	M8x14	M8x14	M10x18	M10x18	M12x20
Pp	29	36.5	43.5	53	57	67	74	81
R	65	75	85	95	115	130	165	215
T	52.5	68.5	82.5	100.5	116.5	131.5	161.5	181
t2	16.3	20.8 (21.8)	28.3 (27.3)	28.3	31.3 (33.3)	38.3	45.3	48.8 (51.8)
X	1.5	1.5	1.5	2	2	2	2.5	3

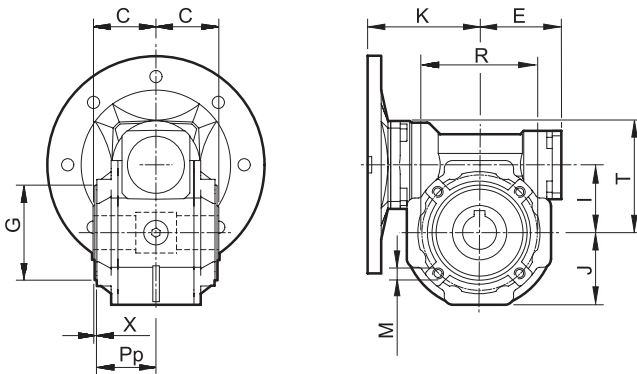

Flangia pendolare / Side cover for shaft mounting / Aufsteckflansch

	Piedi Feet Fuß	30	40	50	63	75	90	110	130
A	1	67	86.5	106	127.5	155.5	190	250	295
	2	67	86.5	106			190	250	
a	1	40-52	70	63-85	95	120	140	200	235
	2	40-52	52	63-85			140	200	220
B	1	78	98	119	136	140	168	210	229
	2	78	98	119			168	210	
b	1	66	84	99	111	115	140	162	190
	2	66	81	99			146	181	191
f	1	6.5	7	9	11	11	13	13	15
	2	6.5	8.5	9			11	13	
H	1	52	71	85	100	115	135	172	200
	2	55	72	82			142	170	195
S	1	5	9	11	12	12	14	17	20
	2	8	10	8			14	15	15

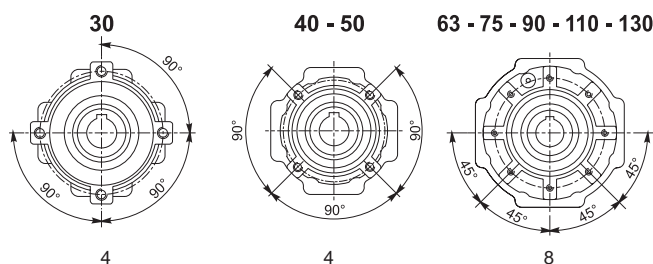

Fori / Holes / Bohrungen Fori / Holes / Bohrungen Fori / Holes / Bohrungen

KC..P

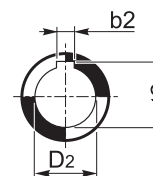

Albero uscita cavo
Hollow output shaft
Abtriebshohlwelle

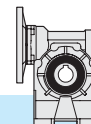

3.7 Dimensioni

3.7 Dimensions

3.7 Abmessungen

Flangia uscita / Output flange / Abtriebsflansch

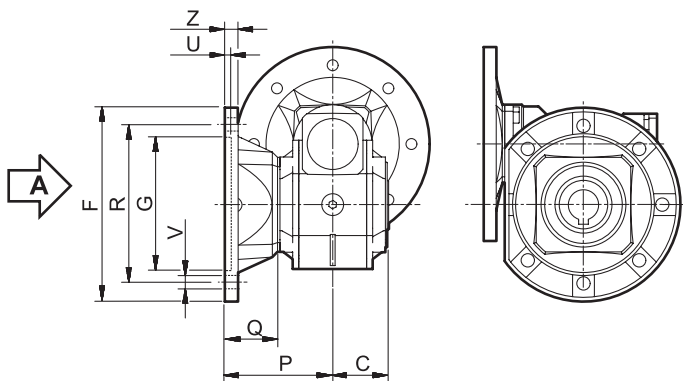

KC..F

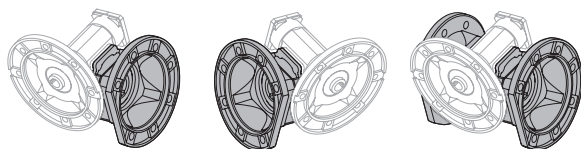

F...D
Standard

F...S

F...2

Vista da A / View from A / Ansicht von A

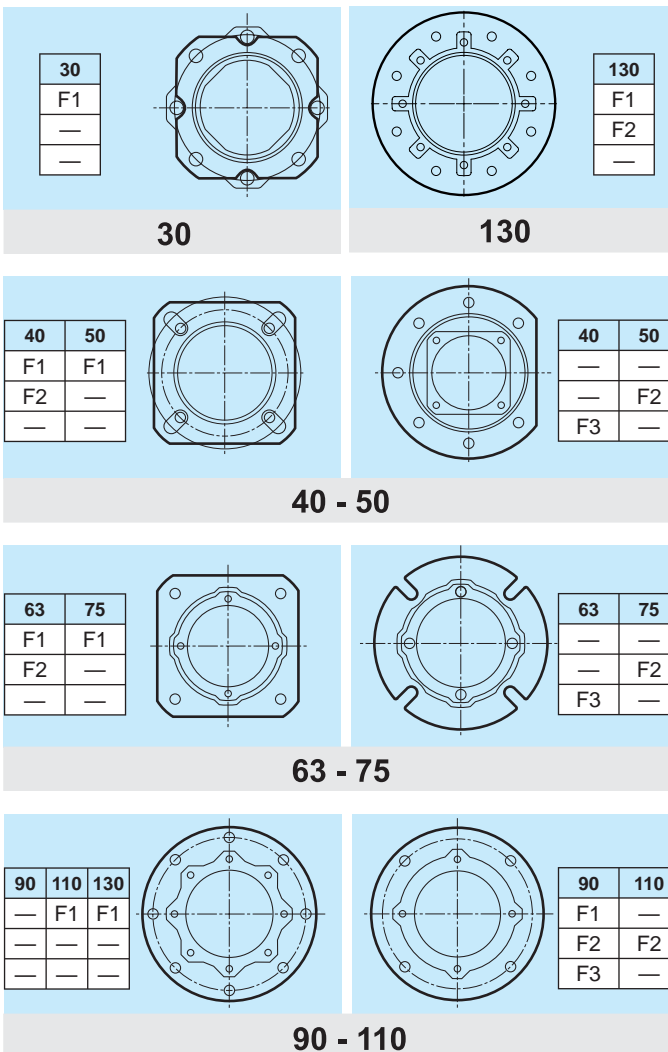

KC	C	F		G H8	P	Q	R	U	V		Z		
30	31.5		66	50	54.5	23	68	4			6.5	6	
40	39		85	60	67	28	75-90	4			9	8	
			85	60	97	58	75-90	4			9	8	
			140	95	80	41	115	5			9	10	
50	46		94	70	90	44	85-100	5			11	10	
			160	110	89	43	130	5			11	11	
63	56		142	115	82	26	150	5			11	11	
			142	115	112	56	150	5			11	11	
			160	110	80.5	24.5	130	5			11	12	
75	60		160	130	111	51	165	5			13	12	
			160	110	90	30	130	6			11	13	
90	70		200	152	111	41	175	5			13	12	
			200	152	151	81	175	5			13	13	
			200	130	110	40	165	6			11	11	
110	77.5		260	170	131	53.5	230	6			13	15	
			250	180	150	72.5	215	5			15	16	
130	85		320	180			255						
			300	230	140	55	265	7			n° 8 *	16	16

* Foratura ruotata di 22.5°

* Drilling turned of 22.5°

* Durchbohrung 22.5° versetzt

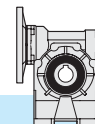

3.8 Entrata supplementare (vite bisporgente)

3.8 Additional input (double extended shaft)

3.8 Zusatzantrieb (beidseitige Welle)

S.e.A.

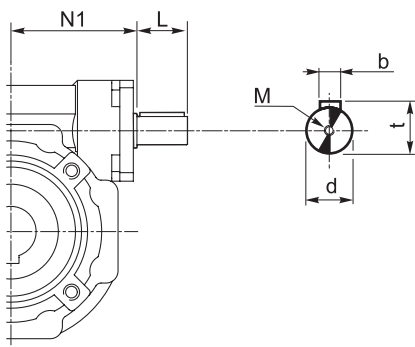

KC	d j6	L	M	N1	b	t
30	9	15	M4x10	42.5	3	10.2
40	11	20	M4x12	52.5	4	12.5
50	14	25	M5x13	62.5	5	16
63	19	30	M8x20	72.5	6	21.5
75	24	40	M8x20	93	8	27
90	24	40	M8x20	108	8	27
110	28	50	M8x20	132.5	8	31
130	38	70	M10x25	152	10	41

3.9 Limitatore di coppia cavo passante

3.9 Torque limiter with through hollow shaft

3.9 Drehmomentbegrenzer mit durchgehender Hohlwelle

Il limitatore di coppia viene consigliato in tutte quelle applicazioni che richiedono una limitazione sulla coppia trasmissibile per proteggere l'impianto e/o preservare il riduttore evitando sovraccarichi o urti indesiderati quanto inaspettati.

È un dispositivo con albero dotato di cavo passante, con funzionamento a frizione, ed è integrato al riduttore, presentando un ingombro limitato.

Concepito per lavorare a bagno d'olio, il dispositivo risulta affidabile nel tempo ed è esente da usura se non viene mantenuto in condizioni prolungate di slittamento (condizione che si verifica quando la coppia presenta valori superiori a quelli di taratura).

La taratura è facilmente regolabile dall'esterno attraverso il serraggio di una ghiera autobloccante che porta a compressione le 4 molle a tazza disposte tra loro in serie.

Il dispositivo non consente:

- l'impiego di cuscinetti a rulli conici in uscita
- funzionamento prolungato in condizioni di slittamento.

Nella tabella seguente vengono riportati i valori delle coppie di slittamento M_{2S} in funzione del n° di giri della ghiera.

I valori di taratura presentano una tolleranza del $\pm 10\%$ e si riferiscono ad una condizione statica.

In condizioni dinamiche è da notare che la coppia di slittamento assume valori diversi a seconda del tipo e/o modalità in cui si verifica il sovraccarico: con valori maggiori in caso di carico uniformemente crescente rispetto a valori più contenuti in seguito al verificarsi di picchi improvvisi di carico.

NOTA: quando si supera il valore di taratura si ha slittamento. Il coefficiente di attrito tra le superfici di contatto da statico diventa dinamico e la coppia trasmessa cala del 30% circa.

E' quindi opportuno prevedere uno stop per poter ripartire al valore di taratura iniziale.

The use of a torque limiter is advisable when the application requires the limitation of the transmissible torque to safeguard the plant and/or the gearbox from unexpected or undesired overloads.

The torque limiter is equipped with a through hollow shaft and a friction clutch. It is integrated in the gearbox, therefore space requirement is limited.

Designed to be working in oil bath, the device is reliable over time and is not subject to wear unless in case of operation with prolonged slipping (it occurs when the torque values are higher than the calibration values).

Calibration can be easily adjusted from outside by tightening of the self-locking ring nut, which causes the compression of the 4 Belleville washers arranged in series.

The device does not go together with:

- the use of tapered roller bearings at output
- prolonged operation under slipping conditions

The following table shows the values of M_{2S} slipping torques depending on the number of revolutions of the ring nut.

Calibration values feature a $\pm 10\%$ tolerance and refer to static conditions.

Under dynamic conditions the values of the slipping torque will change according to the type of overload: the values are higher if the load increase is uniform; the values are lower if sudden load peaks occur.

NOTE: *Slipping occurs when the setting values are exceeded.*

The friction coefficient between the contact surfaces from static becomes dynamic and the transmitted torque is approx. 30% lower.

It is advisable to have a stop first in order to have a restart based on the initial setting value.

Die Anwendung eines Drehmomentbegrenzers wird empfohlen, um die Anlage und/oder das Getriebe gegen ungewünschte und unerwartete Überbelastungen zu schützen.

Es handelt sich um eine Vorrichtung mit einer durchgehender Hohlwelle.

Er ist in dem Getriebe integriert, d.h. der Raumbedarf ist klein. Der Begrenzer wurde für Betrieb in einem Ölbad entworfen.

Er ist zuverlässig über Zeit und verschleißfest (ausser wenn Rutschen für lange Zeit besteht: das passiert, wenn das Drehmoment höher als der Eichwert ist).

Die Eichung darf mühelos von aussen durch das Anziehen einer selbstsperrenden Mutter ausgeführt werden. Das Anziehen verursacht die Zusammendrückung der 4 wechelsinnigeschichteten Tellerfeder.

Die Vorrichtung sieht das folgende nicht vor:

- die Verwendung von Kegelrollenlager am Abtrieb
- Längerer Rutschbetrieb

Die nachstehende Tabelle zeigt die Werte der Rutschmomente M_{2S} abhängig von der Zahl der Umdrehungen der Mutter.

Die Eichwerte weisen $\pm 10\%$ Toleranz auf und beziehen sich auf statische Bedingungen.

Unter dynamischen Bedingungen hat das Rutschmoment verschiedene Werte je nach Art der Überbelastung. Die Werte sind höher, wenn die Belastung gleichmäßig zunimmt; sie sind niedriger im Falle von plötzlichen Belastungsspitzen.

BEMERKUNG: Rutschen tritt auf, wenn die eingestellten Werte überschritten werden. Der Reibungskoeffizient zwischen den Berührungsflächen wird dynamisch anstatt statisch und das übertragene Drehmoment sinkt um ca. 30%.

Es ist daher ratsam, vor dem erneuten Anfahren anzuhalten, um die ursprünglichen Drehmomentwerte zu erreichen.

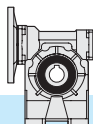

E' importante notare che la coppia di slittamento non resta sempre la medesima durante tutta la vita del limitatore.

Tende infatti a diminuire in rapporto al numero e alla durata degli slittamenti che, rodando le superfici di contatto, ne aumentano il rendimento.

È quindi opportuno verificare periodicamente, soprattutto durante la fase di rodaggio, la taratura del dispositivo.

Là dove sia richiesto un errore più contenuto nella taratura, è necessario testare la coppia trasmissibile sull'impianto.

Il dispositivo viene consegnato tarato alla coppia riportata a catalogo T_{2M} salvo diversa indicazione espressa in fase di ordinazione.

It is important to note that the slipping torque is not the same for the whole life of the torque limiter.

It usually decreases in connection with the numbers and the duration of the slipping which because of the surfaces' lapping will increase the efficiency.

For this reason it is advisable to check the calibration of the device at regular intervals, specially during the running-in period.

Should a smaller calibration error be required, it is necessary to test the transmissible torque on the plant.

The device is supplied already calibrated at the torque reported in the catalogue T_{2M} , unless otherwise specified in the order.

Es ist wichtig zu beachten, dass das Rutschmoment über die gesamte Lebensdauer der Rutschkupplung nicht konstant bleibt, sondern üblicherweise in Verbindung mit längeren Rutschzyklen aufgrund der eingelaufenen Berührungsfächen abnimmt.

Deswegen ist es ratsam, die Eichung der Vorrichtung besonders während der Einlaufzeit zu prüfen.

Falls ein niedriger Eichfehler verlangt wird, ist das übersetzbare Drehmoment auf der Anlage zu testen.

Wenn die Vorrichtung geliefert wird, ist sie schon auf dem im Katalog T_{2M} angegebenen Drehmoment geeicht, ausser wenn es in der Bestellung anders angegeben wird.

KC	N°. giri della ghiera di regolazione / N°. revolutions of ring nut / Nr. Umdrehungen der Mutter											
	1	1 1/4	1 1/2	1 3/4	2	2 1/4	2 1/2	2 3/4	3	3 1/4	1/2	3 3/4
	M_{2S} [Nm]											
30		15	20	23	25							
40	30	37	45									
50		45	55	63	70	77						
63				85	95	110	125	137	150			
75					130	147	165	177	190	205	220	230
90				193	220	247	275	297	320	350	380	
110		425	550	600	700							
130												

Disposizione delle molle
Washers' arrangement
Lage der Feder

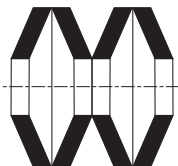

IN SERIE (min. coppia, max. sensibilità)
SERIES (min. torque, max sensitivity)
SERIE (min. Moment, max. Empfindlichkeit)

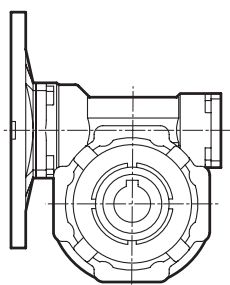
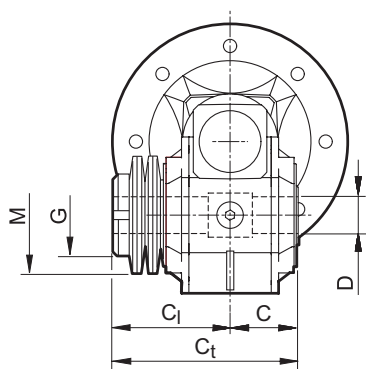

KC	C	C ₁	C _t	D H7	M	G
30	31.5	55.5	87	14	50x25.4x1.25	M25x1.5
40	39	65	104	18 (19)	56x30.5x1.5	M30x1.5
50	46	76	122	25 (24)	63x40.5x1.8	M40x1.5
63	56	91	147	25	71x40.5x2	M40x1.5
75	60	100	160	28 (30)	90x50.5x2.5	M50x1.5
90	70	109	179	35 (32)	100x51x2.7	M50x1.5
110	77.5	127.5	205	42	125x61x4	M60x2.0
130						

() A richiesta / On request / Auf Anfrage

Nella versione con limitatore non è prevista la fornitura degli alberi lenti.

The version with torque limiter is supplied without output shafts.

Die Version mit Drehmomentbegrenzer wird ohne Abtriebswellen geliefert.

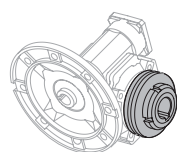

LD

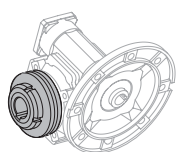

LS



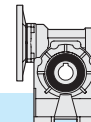

3.10 Accessori

3.10 Accessories

3.10 Accessories

Albero lento

Output shaft

Abtriebswelle

Albero lento semplice
Single output shaft
Standard Abtriebswelle

Albero lento doppio
Double output shaft
Doppelte Abtriebswelle

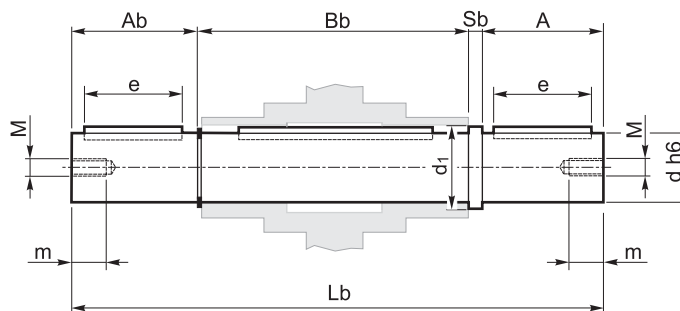
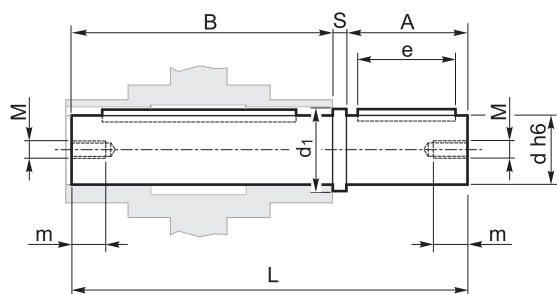

KC	A	A _b	B	B _b	d _{h6}	d ₁	e	L	L _b	M	m	S	S _b
30	30	29	62	64	14	18.5	20	94.5	126	M6	16	2.5	2.5
40	40	39	77	79	18	23.5	30	120	161	M6	16	3	3
50	50	49	90	93	25	31.5	40	143.5	195.5	M8	22	3.5	3.5
63	50	49	111	113	25	31.5	40	165	216	M8	22	4	4
75	60	59	119	121	28	34.5	50	183	244	M8	22	4	4
90	80	78.5	139	141.5	35	41.5	60	224	305	M10	28	5	5
110	80	77.5	154.5	157	42	49.5	60	242.5	322.5	M10	28	8	8
130	80	78	168	172	45	54.5	70	253	335	M16	36	5	5

Braccio di reazione

Torque arm

Drehmomentstütze

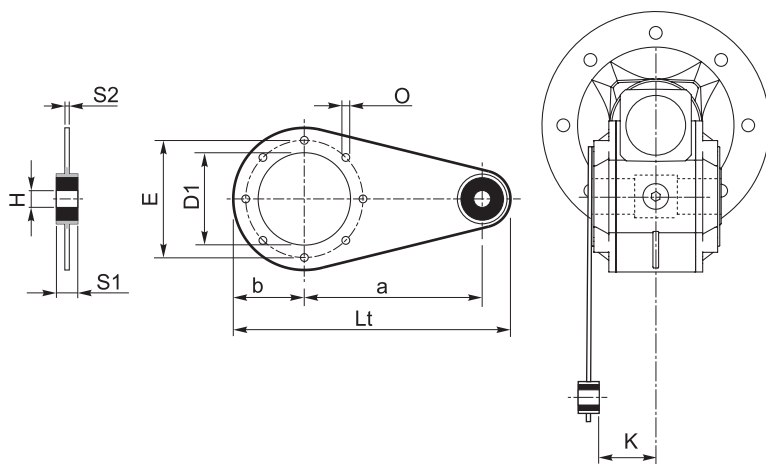

KC	a	b	D ₁	E	H	K	L _t	O	S1	S2
30	85	37.5	55	65	8	24	141.5	7	14	4
40	100	45	60	75	10	31.5	167	7	14	4
50	100	50	70	85	10	39	172	9	14	5
63	150	55	80	95	10	49	227	9	14	6
75	200	70	95	115	20	47.5	302	9	25	6
90	200	80	110	130	20	57.5	312	11	25	6
110	250	100	130	165	25	62	390	11	30	6
130	250	125	180	215	25	69	415	13	30	6

Kit di protezione: solo su versione P

Protection Kit: only for P Version

Schutzvorrichtung: nur für Version P

Albero cavo / Hollow shaft / Hohlwelle

Limitatore di coppia / Torque limiter / Drehmomentbegrenzer

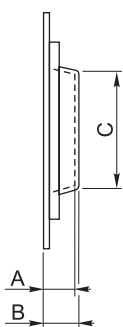

KC	A	B	C
30	12	13	39
40	14	15.5	44
50	15	16.5	54
63	17	19	60
75	18	20	70
90	21.5	24	80
110	22	25	96
130			

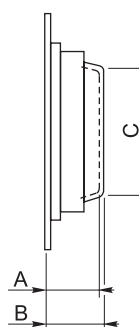

KC	A	B	C
30	36	37	36
40	40	41.5	44
50	47	48.5	53
63	52	54	55
75	58	60	68
90	60.5	63	70
110	72	75	85
130			

Opzioni disponibili:

Available options:

Auf Anfrage ist folgendes Zubehör erhältlich:

Cuscinetti a rulli conici corona

Tapered roller bearing for worm wheel

Kegelrollenlager für Schneckenrad



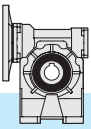

KC

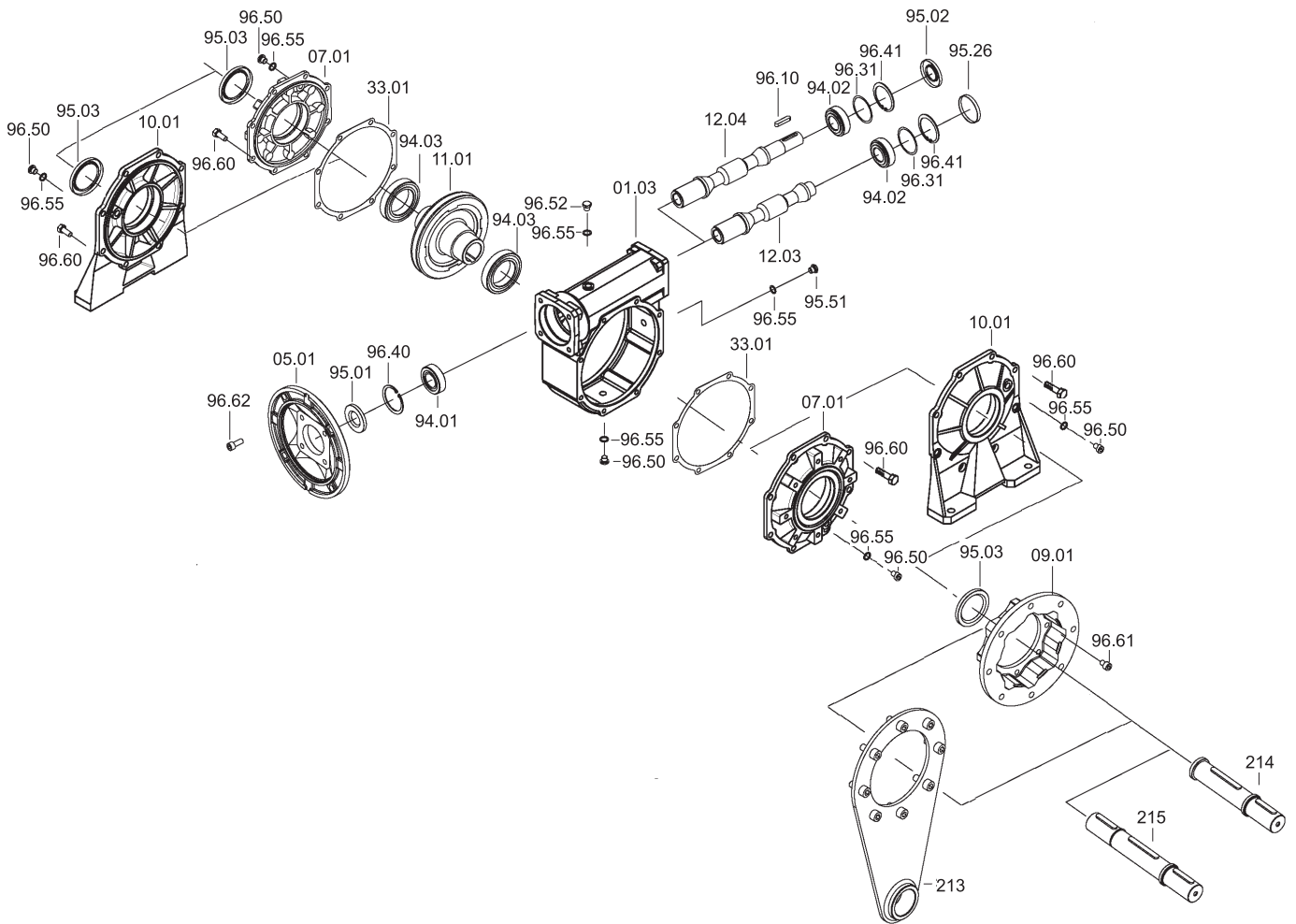

KC	IEC	Cuscinetti / Bearings / Lager			Anelli di tenuta / Oilseals Öldichtungen			Cappellotto / Closed oil seal Geschlossene Öldichtung
		94.01	94.02	94.03	95.01	95.02	95.03	95.26
30	56	61804 (20x32x7)	6000 10x26x8	6005 25x47x12	20/32/7	10/26/7	25/40/7	ø 26x7
	63	61804 (20x32x7)			20/32/7			
40	56	6303 (17x47x14)	6201 12x32x10	6006 30x55x13	17/47/7	12/32/7	30/47/7	ø 32x7
	63	6204 (20x47x14)			20/47/7			
	71	6005 (25x47x12)			25/47/7			
50	63	6204 (20x47x14)	6203 17x40x12	6008 40x68x15	20/47/7	17/40/7	40/62/8	ø 40x7
	71	6005 (25x47x12)			25/47/7			
	80	6006 (30x55x13)			30/55/7			
63	71	30305 (25x62x18.25)	30204 20x47x15.25	6008 40x68x15	25/62/7	20/47/7	40/62/8	ø 47x7
	80	30206 (30x62x17.25)			30/62/7			
	90	32007 (35x62x18)			35/62/7			
75	80	30206 (30x62x17.25)	30205 25x52x16.25	6010 50x80x16	30/62/7	25/52/7	50/72/8	ø 52x7
	90	32007 (35x62x18)			35/62/7			
	100/112	32008 (40x68x19)			40/68/10			
90	80	30206 (30x62x17.25)	32205B 25x52x19.25	6010 50x80x16	30/62/7	25/52/7	50/72/8	ø 52x7
	90	32007 (35x62x18)			35/62/7			
	100/112	32008 (40x68x19)			40/68/10			
110	90	30208 (40x80x19.75)	32206B 30x62x21.25	6012 60x95x18	40/80/10	30/62/7	60/85/8	ø 62x7
	100/112	30208 (40x80x19.75)			40/80/10			
	132	32010 (50x80x20)			50/80/10			
130	90	30208 (40x80x19.75)	33208 40x80x32	6015 75x115x20	40/80/10	40/80/10	75/100/10	ø 80x10
	100/112	30208 (40x80x19.75)			40/80/10			
	132	32010 (50x80x20)			50/80/10			