

2.0

RIDUTTORE AD ASSI ORTOGONALI

BEVEL HELICAL GEARBOX

KEGELSTIRNRADGETRIEBE

2.1	Caratteristiche	<i>Characteristics</i>	Merkmale	12
2.2	Designazione	<i>Designation</i>	Bezeichnung	13
2.3	Sensi di rotazione alberi	<i>Direction of shaft rotation</i>	Drehrichtungen der Wellen	14
2.4	Entrata supplementare	<i>Additional input</i>	Zusatzantrieb	14
2.5	Rendimento	<i>Efficiency</i>	Wirkungsgrad	14
2.6	Velocità in entrata	<i>Input speed</i>	Antriebsdrehzahl	15
2.7	Potenza termica	<i>Thermal power</i>	Thermische Leistung	15
2.8	Dati tecnici	<i>Technical data</i>	Technische Daten	16
2.9	Momenti d'inerzia	<i>Moments of inertia</i>	Trägheitsmoment	18
2.10	Dimensioni	<i>Dimensions</i>	Abmessungen	24
2.11	Accessori	<i>Accessories</i>	Zubehör	30
2.12	Giochi angolari	<i>Angular backlash</i>	Winkelspiel	34
2.13	Lubrificazione	<i>Lubrication</i>	Schmierung	34
2.14	Carichi radiali e assiali	<i>Radial and axial loads</i>	Radial- und Axialbelastungen	36
2.15	Lista parti di ricambio	<i>Spare parts list</i>	Ersatzteilliste	38

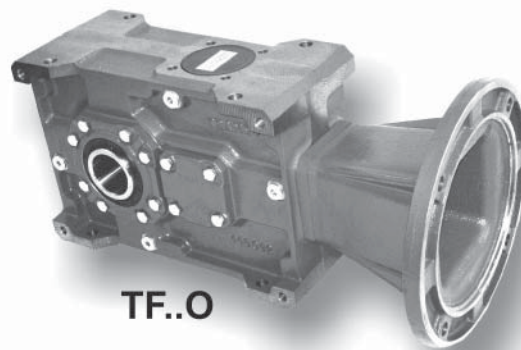

TF..O

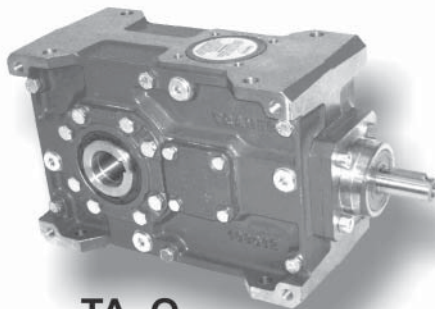

TA..O

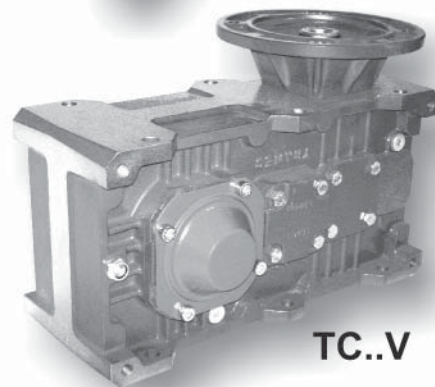

TC..V

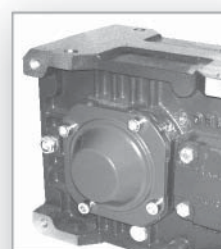
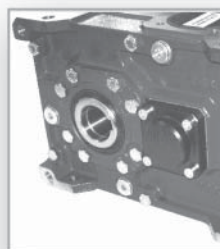
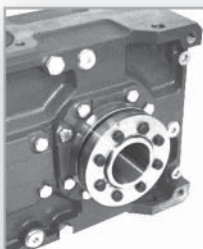

06/2011

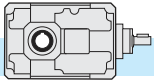

2.1 Caratteristiche

- Costruiti in 9 grandezze a 2 riduzioni e in 8 grandezze a 3 riduzioni.
- Sono previsti tre tipi di entrata: con albero entrata sporgente, con predisposizione attacco motore (campana e giunto) e predisposizione attacco motore COMPATTA, escluse grandezze 56 e 63. I tre tipi di entrata possono essere montati indifferentemente nelle esecuzioni verticale e/o orizzontale.
- Il corpo riduttore in lega di alluminio, $GAISi9Cu1$ UNI7369/3 (56-63), in ghisa meccanica EN GJL 200 UNI EN 1561 (71-180) o in ghisa sferoidale EN GJS 400-15U UNI EN1563 (200-225), abbondantemente nervato all'interno e all'esterno per garantire la rigidità, è lavorato su tutti i piani per consentire un facile posizionamento; inoltre un'unica camera di lubrificazione garantisce una maggiore dissipazione termica e una migliore lubrificazione di tutti gli organi interni.
- Gli ingranaggi sono costruiti in acciaio legato da cementazione e sottoposti a trattamento di cementazione e tempra. In particolare, la prima riduzione è costituita da due ingranaggi conici a dentatura spiroidale GLEASON con profilo accuratamente rodato, in acciaio 16NiCr4 o 18NiCrMo5 cementati e temprati. Gli ingranaggi cilindrici, a dentatura elicoidale, sono costruiti in acciaio 16NiCr4, 18NiCrMo5 o 20MnCr5 UNI EN 10084 cementati e temprati, rettificati entro la classe di qualità 6 della DIN 3962.
- L'utilizzo dei cuscinetti a rulli conici di qualità su tutti gli assi (ad eccezione del manicotto in entrata nella predisposizione attacco motore compatta, il quale è sostenuto da cuscinetti obliqui a sfere) consente al riduttore di ottenere delle durate molto elevate e di sopportare dei carichi radiali e assiali esterni molto elevati.
- L'albero lento cavo di serie in acciaio (disponibile a richiesta con calettatore), la possibilità di montare una flangia uscita su uno o entrambi i fianchi laterali e la predisposizione per il montaggio del dispositivo antiritorno esaltano la versatilità di questi riduttori facilitandone l'installazione.
- Il corpo riduttore, le flange, le campane ed i coperchi vengono verniciati esternamente di colore BLU RAL 5010, ad eccezione dei riduttori ortogonali delle grandezze 56 e 63, realizzati in alluminio.

2.1 Characteristics

- *Built in 9 sizes with 2 reduction stages and in 8 sizes with 3 reduction stages.*
- *Three input types are available : projecting input shaft, pre-engineered motor coupling (bell and joint) and pre-engineered COMPACT motor coupling. (Size 56 and 63 excluded). The 3 input types can be mounted either vertically and/or horizontally.*
- *Gear unit casing in aluminium alloy $GAISi9Cu1$ UNI7369/3 (56-63), in engineering cast iron, EN GJL 200 UNI EN 1561 (71-180) or spheroidal graphite cast iron EN GJS 400-15U UNI EN 1563 (200-225), is ribbed internally and externally to guarantee rigidity. It is machined on all surfaces for easy positioning. The single lubrication chamber guarantees improved heat dissipation and improved lubrication of all the internal components.*
- *The gears are built in casehardened compound steel and have undergone case-hardening and quench-hardening treatments. In particular, the first reduction stage consists of two GLEASON spiral bevel gears with precision ground profile, in 16CrNi4 or 18NiCrMo5 case-hardened and quench-hardened steel. The helical spur gears are built in 16NiCr4, 18NiCrMo5 or 20MnCr5 UNI EN 10084 quench-hardened and case-hardened steel, grinded in quality 6 DIN 3962.*
- *The use of high-quality tapered roller bearings on all shafts (except for the input sleeve on the pre-engineered compact motor coupling, which is supported by angular ball bearings) ensures long life and enables very high external radial and axial loads.*
- *The standard hollow output shaft made of steel (shrink disc available on request), the option of mounting an output flange on one or both sides and the possibility of mounting a backstop device make these gear units extremely versatile and easy to install.*
- *Gearbox housing, flanges, bells and covers are externally painted with BLUE RAL 5010, except for bevel helical gearboxes size 56 and size 63 which are made in aluminium.*

2.1 Merkmale

- Erhältlich in 9 Größen zu je 2 Untersetzungsstufen und in 8 Größen zu je 3 Untersetzungsstufen.
- Vorgesehen sind drei Antriebsarten: mit vorstehender Antriebswelle, mit Auslegung für Motoranschluß (Glocke und Kupplung), mit Kompaktauslegung für Motoranschluß (Baugröße 56 und 63 ausgenommen). Die drei Antriebstypen können alle sowohl in der vertikalen als auch in der horizontalen Ausführung verwendet werden.
- Die Getriebegehäuse ist aus Aluminiumlegierung $GAISi9Cu1$ UNI7369/3 (56-63), Maschinenguß EN GJL 200 UNI EN 1561 (71-180) oder aus Sphäroguß EN GJS 400-15U UNI EN 1563 (200-225) und mit Rippen versehen, die die Steifheit gewährleisten; die Bearbeitung aller Flächen ermöglicht eine leichte Positionierung; eine einzige Schmierkammer gewährleistet eine höhere Wärmedissipation und eine bessere Schmierung aller inneren Elemente.
- Die Zahnräder bestehen aus legiertem Einsatzstahl, sie wurden einsatz- und abschreckgehärtet. Insbesondere, die erste Untersetzungsstufe besteht aus zwei spiralverzahnten GLEASON – Kegelrädern mit sorgfältig eingelaufenem Profil aus einsatz- und abschreckgehärtetem 16CrNi4- oder 18NiCrMo5. Die Schrägstirnräder bestehen aus einsatz- und abschreckgehärtetem 16NiCr4, 18NiCrMo5- oder 20MnCr5-Stahl UNI EN 10084, geschliffen innerhalb Qualitätsklasse 6 der Spez. DIN 3962.
- An allen Achsen werden Qualitäts-Kegelrollenlager eingebaut. Diese gewährleisten eine hohe Lebensdauer und das Aushalten von sehr hohen Radial- und Axialbelastungen. (Ausnahme: Muffe am Antrieb bei Kompaktauslegung die von Schrägkugellagern gehalten wird)
- Die serienmäßige Abtriebshohlwelle aus Stahl (auf Wunsch mit Schrumpfscheibe erhältlich), die Möglichkeit der Montage eines Abtriebsflansches an einer oder an beiden Seiten und die Auslegung für die Montage der Rücklaufsperrung heben die Vielseitigkeit dieser Untersetzungsgetriebe hervor und erleichtern ihren Einbau.
- Getriebegehäuse, Flansche, Glocken und Deckel werden in BLAU RAL 5010 lackiert (mit Ausnahme von Kegelstirnradgetriebe Größe 56 und 63, die aus Aluminium bestehen).

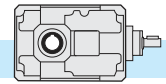

2.2 Designazione

2.2 Designation

2.2 Bezeichnung

Riduttore Gearbox Getriebe	Tipo entrata Input type Antriebsart	Grandezza Size Größe	Rotismo Gearing Räderwerk	Rapporto rid. Ratio Untersetzungsverhältnis	Predisp. posiz. Motor coupling Motoranschluss	Esecuzione Execution Ausführung	Posizione di montaggio Mounting position Baulage	Flangia uscita Output flange Abtriebsflansch	Antririttorno Back-stop device Rücklaufsperre	Calettatore Shrink disk Schrumpfscheibe	Entrata supplementare Additional input Zusatzantrieb
T	A	112	B	10/1	P.A.M.	O	B3	FLS	CW	C.S.	S.e.A.
Riduttore ad assi ortogonali Bevel/helical gearbox Kegelstirnradgetriebe	A	56 63 71 90 112 140 180 200 225	B	in = .../1 5 + 630	56 ÷ 225	O	B3 B6 B7 B8 VA VB	FLS	AW	C.S.	A
	C	56 63 80 100 125 160 180 200	C			V		FLD	CW	C.D.	C
	F							2FL			F

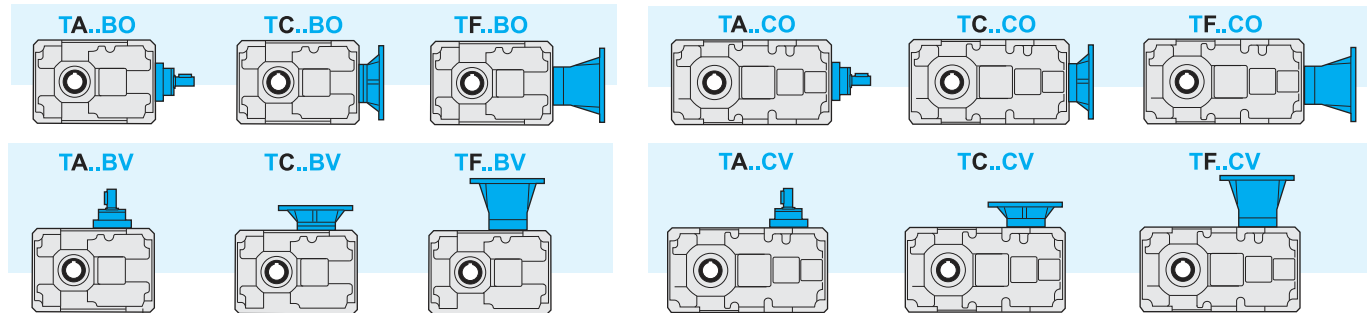

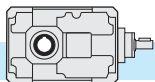

2.3 Sensi di rotazione alberi

Nei riduttori esecuzione orizzontale, per ottenere il senso di rotazione contrario al catalogo dell'albero lento mantenendo invariato il senso di rotazione dell'albero veloce, è sufficiente ruotare il riduttore di 180° attorno all'asse dell'albero veloce, utilizzando in pratica il piano di fissaggio opposto.

Nei riduttori esecuzione verticale è possibile fornire il senso di rotazione contrario al catalogo specificandolo al momento dell'ordine.

2.3 Direction of shaft rotation

With regard to horizontal mounted gearboxes, in order to get output rotation in a direction opposite to that given in the catalogue, nevertheless keeping input rotation direction unchanged, simply turn the gearbox 180° around the input shaft; in practice, mount the other way up.

Vertical units can be supplied with rotation direction opposite to that given in the catalogue; specify when ordering.

2.3 Drehrichtungen der Wellen

Wenn bei Untersetzungsgetrieben in waagerechter Ausführung für die Abtriebswelle eine andere als die im Katalog angegebene Drehrichtung gewünscht wird und die Antriebswelle ihre Drehrichtung beibehalten soll, so genügt es, das Getriebe um 180° um die Achse der Antriebswelle zu drehen, d.h. die gegenüberliegende Anschlußfläche zu verwenden.

Untersetzungsgetrieben in vertikaler Ausführung sind mit gegensätzlicher Drehrichtung lieferbar, deswegen ist es bei der Bestellung anzugeben, falls die umgekehrte Drehrichtung gewünscht wird.

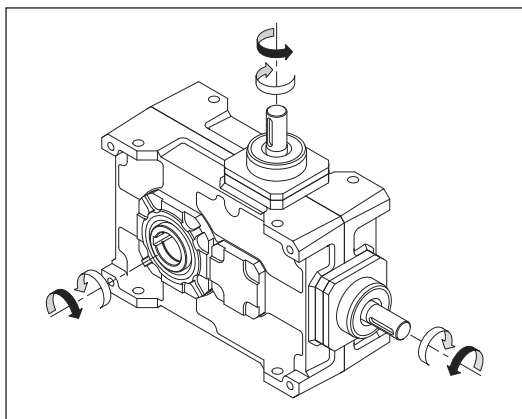

Sensi di rotazione standard
Standard direction of rotation
Standarddrehrichtungen.

2.4 Entrata supplementare

L'albero entrata può essere montato nella posizione orizzontale (O) o verticale (V), eccetto le grandezze 56 e 63. Il cambio di versione può essere facilmente realizzato anche successivamente al primo montaggio.

Eccetto le grandezze 56 e 63, esiste la possibilità di montare una seconda entrata scegliendola, in base alle necessità, tra quelle previste: TA, TC, TF.

In questo caso occorre definire la versione del riduttore con l'entrata principale e specificare quindi la seconda entrata.

2.4 Additional input

The input shaft can be mounted either horizontally (O) or vertically (V) on all sizes except for 56 and 63. The version can be easily changed even after the first assembly.

Except for sizes 56 and 63, there is the possibility of mounting a second input; the available options are TA, TC, TF.

Both the main input and the additional second input shall be specified when ordering.

2.4 Zusatzantrieb

Die Antriebswelle kann entweder waagrecht (O) oder senkrecht (V) montiert werden ((Baugröße 56 und 63 ausgenommen). Auch nach der ersten Montage kann die Version leicht geändert werden. Mit Ausnahme von den Größen 56 und 63 kann ein zweiter Antrieb TA, TC oder TF montiert werden.

Bei der Bestellung sollte sowohl der hauptsächliche Antrieb als auch der zweite Antrieb angegeben werden.

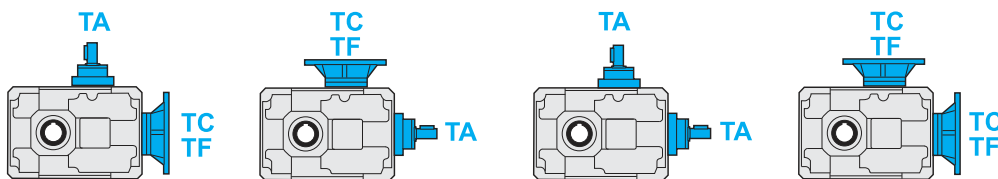

2.5 Rendimento

Il valore del rendimento dei riduttori può essere stimato con sufficiente approssimazione in base al numero di riduzioni, trascurando le variazioni non significative attribuibili alle varie grandezze e rapporti.

2.5 Efficiency

The efficiency value of the gear units can be estimated sufficiently well on the basis of the number of reduction stages, ignoring non-significant variations which can be attributed to the various sizes and ratios.

2.5 Wirkungsgrad

Der Wirkungsgrad des Getriebes kann mit ausreichender Annäherung aufgrund der Anzahl der Untersetzungsstufen ermittelt werden. Dabei können die unwesentlichen Veränderungen, die auf die verschiedenen Größen und Untersetzungsverhältnisse zurückzuführen sind, ausser Acht gelassen werden.

η	T...B	T...C
	0.95	0.93

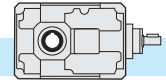

2.6 Velocità in entrata

Tutte le prestazioni dei riduttori sono calcolate in base ad una velocità in entrata di 1400 min⁻¹.

Tutti i riduttori ammettono velocità fino a 3000 min⁻¹ anche se è consigliabile, dove l'applicazione lo permette, utilizzare valori inferiori a 1400 min⁻¹.

Nella tabella sottostante riportiamo i coefficienti correttivi della potenza in entrata P alle varie velocità riferita ad Fs = 1

2.6 Input speed

All calculations of gear unit performance are based on an input speed of 1400 min⁻¹. All gear units permit speed up to 3000 min⁻¹, nevertheless it is advisable to keep below 1400 min⁻¹, depending on application.

The table below reports input power P corrective coefficients at the various speeds, with Fs = 1.

2.6 Antriebsdrehzahl

Bei der Berechnung der Getriebeleistungen wurde eine Antriebsdrehzahl von 1400 min⁻¹ berücksichtigt.

Bei allen Getrieben sind Antriebsdrehzahlen bis 3000 min⁻¹ möglich; es ist jedoch ratsam, die Drehzahlen unter 1400 min⁻¹ zu halten, wenn die Anwendung es ermöglicht.

In der folgenden Tabelle finden Sie die Korrekturkoeffizienten für die Antriebsleistung P bei den verschiedenen Drehzahlen, bezogen auf Fs = 1.

Tab. 1

n ₁ (rpm)	3000	2800	2200	1800	1400	900	700	500
P _c (kW)	P x 1.9	P x 1.8	P x 1.48	P x 1.24	P x 1	P x 0.7	P x 0.56	P x 0.42

2.7 Potenza termica

I valori delle potenze termiche, P₁₀ (kW), sono riportati nella tabella seguente, in funzione di grandezza, rapporto e velocità entrata del riduttore.

I valori sono calcolati considerando l'utilizzo di olio sintetico ISO 320.

Vedere paragrafo 1.4 per la scelta dei fattori correttivi.

2.7 Thermal power

The following table shows the values of thermal power P₁₀ (kW) for each gearbox size on the basis of ratio and input speed.

The values have been calculated considering the utilization of synthetic oil ISO 320. See chapter 1.4 for the corrective coefficients.

2.7 Thermische Leistung

Die folgende Tabelle enthält die Werte P₁₀ der thermischen Leistung (kW) je nach Getriebegröße und abhängig von Untersetzung und von Drehzahlen am Getriebeantrieb. Die angegebenen Werte beziehen sich auf Schmiering mit synthetischen Öl ISO 320.

Im Abschnitt 1.4 finden Sie die Korrekturkoeffizienten.

Potenza Termica / Thermal power / Thermische Leistung P ₁₀ [kW]																		
i _n	T56B		T63B		T71B		T90B		T112B		T140B		T180B		T200B		T225B	
	1400	2800	1400	2800	1400	2800	1400	2800	1400	2800	1400	2800	1400	2800	1400	2800	1400	2800
8					-	-	-	-	-	-	-	-	-	-	48.3	45.4	59	48
10					4	6.3	10.8	17	32	43.3	42	55	45.8					
12.5					3.7	5.8	10	15.5	28.7	39	38.5	49	41.5					
16					3.3	5.2	9	14	25.8	33.8	37							
20	4	3.4	5.5	4.7	2.8	4.4	7.7	11.8	23.5	30.8	35							
25					2.7	4.2	7.3	11	21.6	28.6	32.3							
31.5					2.5	3.9	6.8	10.4	20	25.6	27.7							
40					2.3	3.6	6.3	9.5	18	23.9	25.8							
50					1.9	3	4.7	7.6	11.3	17.4	-							
63					1.8	2.8	4.4	7.3	10.7	16.6	-							
80	-	-	-	-	1.7	2.6	4.2	6.8	10	-	-							

Potenza Termica / Thermal power / Thermische Leistung P ₁₀ [kW]																
i _n	T56C		T63C		T80C		T100C		T125C		T160C		T180C		T200C	
	1400	2800	1400	2800	1400	2800	1400	2800	1400	2800	1400	2800	1400	2800	1400	2800
40					-	-	-	-	-	-	-	-	-	-	32	34.2
50					3.6	5.8	9.7	16.8	18.2	21	23.3	30.7	32.6			
63					3.4	5.3	9	15.5	17	19.5	21.6	28.5	30			
80					3.2	5	8.6	14.6	16	18.4	20.4	26.4	27.7			
100	3.3	2.8	4.2	3.6	2.9	4.5	7.7	13	14	17	18.4	24.8	27			
125					2.7	4.2	7.3	12.3	13.2	15.6	17	23.3	25.3			
160					2.6	4	7	11.7	12.5	14.7	16	21.8	23.5			
200					2.5	4	6.6	11	12	13.6	14.7	16	17.5			
250					2.2	3.3	5.3	9.3	10	12	12.8	15.3	16.7			
315					2	3.2	5.2	9	9.7	11.4	12.3	14.6	15.8			
400					2	3	5	8.6	9.3	10.7	11.5	-	-			
500					2	3	4.7	8	8.6	-	-	-	-			
630					2	3	4.6	7.8	8.4	-	-	-	-			

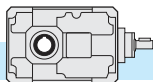

2.8 Dati tecnici

2.8 Technical data

2.8 Technische Daten

T	n ₁ = 1400			TC - TF				TA	
	in	ir	n ₂ rpm	T ₂ Nm	P1 kW	FS'	IEC	T _{2M} Nm	P kW
56B	8	8.06	174	94	1.8	1.2		110	2.1
	10	10.17	138	120	1.8	1.0	56	120	1.8
	12.5	12.31	114	120	1.5	1.1	63 (B5)	130	1.6
	16	15.00	93	107	1.1	1.3	71	140	1.4
	20	20.33	69	140	1.1	1.0	80	140	1.1
	25	24.62	57	140	0.9	1.0	90 (B5)	140	0.90
	31.5	30.00	47	107	0.55	1.3	(B14)	140	0.70
	40	39.38	36	140	0.55	1.0	TF	140	0.55
	50	48.00	29	115	0.37	1.2		140	0.45
56C	40	40.28	35	140	0.55	1.0		140	0.55
	50	50.83	28	119	0.37	1.2	56	140	0.45
	63	61.54	23	140	0.37	1.0	63 (B5)	140	0.37
	80	75.00	19	119	0.25	1.2	71	145	0.30
	100	101.67	14	145	0.22	1.0	80	145	0.22
	125	123.08	11	141	0.18	1.0	90 (B5)	145	0.19
	160	150.00	9	124	0.13	1.2	(B14)	145	0.15
	200	196.92	7	136	0.11	1.1	TF	145	0.12
	250	240.00	6	135	0.09	1.0		135	0.09
63B	8	7.94	176	93	1.8	1.7		155	3.0
	10	10.18	138	119	1.8	1.4	56	170	2.6
	12.5	12.50	112	146	1.8	1.3	63 (B5)	185	2.3
	16	15.88	88	185	1.8	1.0	71	185	1.8
	20	20.36	69	200	1.5	1.0	80	200	1.5
	25	25.00	56	180	1.1	1.1	90 (B5)	200	1.2
	31.5	31.00	45	181	0.9	1.1	(B14)	200	1.0
	40	40.00	35	194	0.75	1.0	TF	200	0.80
	50	49.60	28	177	0.55	1.0		200	0.60
63C	40	39.71	35	194	0.75	1.0		200	0.80
	50	50.89	28	178	0.55	1.2	56	210	0.65
	63	62.50	22	210	0.55	1.0	63 (B5)	210	0.55
	80	79.41	18	186	0.37	1.1	71	210	0.42
	100	101.79	14	161	0.25	1.3	80	210	0.33
	125	125.00	11	198	0.25	1.0	90 (B5)	210	0.26
	160	155.00	9	210	0.22	1.0	(B14)	210	0.22
	200	200.00	7	165	0.13	1.3	TF	210	0.17
	250	248.00	6	200	0.13	1.0		200	0.13
71B	10	10.25	137	120	1.8	1.9		230	3.5
	12.5	13.05	107	152	1.8	1.6	63	240	2.8
	16	15.63	90	182	1.8	1.4	71	250	2.5
	20	19.64	71	229	1.8	1.3	80 (B5)	290	2.3
	25	24.99	56	243	1.5	1.2	90	280	1.7
	31.5	29.95	47	213	1.1	1.2	TC-TF	260	1.3
	40	38.73	36	226	0.9	1.1	80	240	1.0
	50	50.18	28	244	0.75	1.1	(B14)	260	0.80
	63	60.13	23	214	0.55	1.2	TC	260	0.70
80	77.76	18	186	0.37	1.3		240	0.50	

T	n ₁ = 1400			TC - TF				TA	
	in	ir	n ₂ rpm	T ₂ Nm	P1 kW	FS'	IEC	T _{2M} Nm	P kW
90B	5*	4.56	307	118	4	1.8		210	7.2
	6.3*	6.26	224	162	4	1.8		290	7.2
	10	10.25	137	266	4	1.8	71	480	7.2
	12.5	13.05	107	338	4	1.6	80	530	6.3
	16	15.63	90	405	4	1.4	90	550	5.4
	20	19.64	71	509	4	1.2	100 112 (B5)	620	4.9
	25	24.99	56	630	4	1.0	TC-TF	630	4.0
	31.5	29.95	47	560	3	1.0	90*	560	3.0
	40	38.73	36	452	1.8	1.1	(B14)	500	2.0
	50	50.18	28	488	1.5	1.1	TC	550	1.7
80C	50	52.18	27	596	1.8	1.1		660	2.0
	63	62.53	22	595	1.5	1.1	63	680	1.7
	80	79.58	18	555	1.1	1.3	71	710	1.4
	100	99.97	14	698	1.1	1.1	80	740	1.2
	125	119.78	12	684	0.9	1.1	90 (B5)	740	1.0
	160	152.45	9	532	0.55	1.3	TC-TF	680	0.70
	200	182.67	8	637	0.55	1.1	80	700	0.60
	250	240.51	6	565	0.37	1.3	(B14)	750	0.49
	315	306.11	5	719	0.37	1.0	TC	740	0.38
	400	366.78	4	582	0.25	1.2		700	0.30
112B	5*	4.86	288	290	9.2	1.5		430	13.9
	10	10.25	137	611	9.2	1.5		920	13.9
	12.5	13.05	107	778	9.2	1.3	80	1000	11.8
	16	15.63	90	932	9.2	1.2	90	1100	10.9
	20	19.64	71	1171	9.2	1.0	100	1190	9.4
	25	24.99	56	1215	7.5	1.1	112 132 (B5)	1280	7.9
	31.5	29.95	47	1067	5.5	1.1	TC-TF	1220	6.3
	40	38.73	36	1004	4	1.0		1050	4.2
	50	50.18	28	976	3	1.1		1070	3.3
	63	60.13	23	857	2.2	1.3		1140	2.9
100C	50	52.18	27	993	3	1.3		1300	3.9
	63	62.53	22	1190	3	1.1	71	1350	3.4
	80	79.58	18	1111	2.2	1.3	80	1410	2.8
	100	99.97	14	1395	2.2	1.1	90	1470	2.3
	125	119.78	12	1368	1.8	1.1	100	1480	1.9
	160	152.45	9	1064	1.1	1.3	112 (B5)	1360	1.4
	200	182.67	8	1275	1.1	1.1	TC-TF	1400	1.2
	250	240.51	6	1330	0.9	1.1		1500	1.0
	315	306.11	5	1456	0.75	1.1	90*	1480	0.80
	400	366.78	4	1280	0.55	1.1	(B14)	1400	0.60
56B	50	50.18	28	488	1.5	1.1	TC	550	1.7
	63	60.13	23	570	1.5	1.0		570	1.5
	80	77.76	18	454	0.9	1.1		505	1.0
	80	77.76	18	454	0.9	1.1		505	1.0

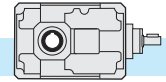

2.8 Dati tecnici

2.8 Technical data

2.8 Technische Daten

T	n ₁ = 1400			TC - TF				TA	
	in	ir	n ₂ rpm	T ₂ Nm	P1 kW	FS'	IEC	T _{2M} Nm	P kW
140B	7*	6.88	203	983	22	1.3		1200	27.9
	10	10.25	137	1461	22	1.3		1850	27.9
	12.5	13.05	107	1860	22	1.1	80	2050	24.3
	16	15.63	90	1874	18.5	1.2	90	2200	21.7
	20	19.64	71	2354	18.5	1.0	100	2400	18.9
	25	24.99	56	2429	15	1.0	112	2540	15.7
	31.5	29.95	47	2135	11	1.1	132	2300	11.9
	40	38.73	36	1882	7.5	1.2	160	2210	8.8
	50	50.18	28	1789	5.5	1.2	180	2120	6.5
	63	60.13	23	2143	5.5	1.1	(B5)	2350	6.0
80	77.76	18	2016	4	1.1	TC-TF	2250	4.5	
125C	50	52.18	27	2483	7.5	1.1		2650	8.0
	63	62.53	22	2182	5.5	1.3		2760	7.0
	80	79.58	18	2777	5.5	1.0		2880	5.7
	100	99.97	14	2537	4	1.2	80	3000	4.7
	125	119.78	12	3000	4	1.0	90	3000	4.0
	160	152.45	9	2128	2.2	1.3	100	2720	2.8
	200	182.67	8	2549	2.2	1.1	112	2800	2.4
	250	240.51	6	2746	1.8	1.1	132	3050	2.0
	315	306.11	5	2913	1.5	1.0	(B5)	2960	1.5
	400	366.78	4	2560	1.1	1.1	TC-TF	2800	1.2
500	474.35	3	2640	0.90	1.0		2640	0.90	
630	613.46	2	2140	0.55	1.2		2550	0.70	
180B	10	10.25	137	1993	30	2.0		3900	58.7
	12.5	13.05	107	2536	30	1.7		4300	50.9
	16	15.63	90	3039	30	1.5	100	4500	44.4
	20	19.64	71	3818	30	1.3	112	5100	40.1
	25	24.99	56	4859	30	1.1	132	5230	32.3
	31.5	29.95	47	4269	22	1.1	160	4680	24.1
	40	38.73	36	3764	15	1.1	180	4300	17.1
	50	50.18	28	3577	11	1.2	200	4300	13.2
	63	60.13	23	4286	11	1.1	(B5)	4780	12.3
80	77.76	18	3779	7.5	1.2	TC-TF	4380	8.7	
160C	50	52.18	27	4966	15	1.0		5130	15.5
	63	62.53	22	4363	11	1.2		5350	13.5
	80	79.58	18	5570	11	1.0	80	5570	11.0
	100	99.97	14	5800	9.2	1.0	90	5800	9.2
	125	119.78	12	5699	7.5	1.0	100	5800	7.6
	160	152.45	9	5319	5.5	1.0	112	5470	5.7
	200	182.67	8	4635	4	1.2	132	5560	4.8
	250	240.51	6	5890	4	1.0	160	5890	4.0
	315	306.11	5	5920	3	1.0	180	5826	3.0
	400	366.78	4	5119	2.2	1.1	(B5)	5600	2.4
	500	474.35	3	5280	1.8	1.0	TC-TF	5280	1.8
	630	613.46	2	4281	1.1	1.2		4960	1.3

T	n ₁ = 1400			TC - TF				TA	
	in	ir	n ₂ rpm	T ₂ Nm	P1 kW	FS'	IEC	T _{2M} Nm	P kW
200B	8	8.14	172	2370	45	2.1		5000	94.8
	10	10.43	134	3050	45	1.8	112	5500	81.4
	12.5	12.60	111	3680	45	1.6	132	6000	73.5
	16	15.63	90	4540	45	1.4	160	6500	64.2
	20	17.65	79	5170	45	1.3	180	7100	62.1
	25	24.14	58	7030	45	1.0	200	7150	45.7
	31.5	29.95	47	7150	37	1.0	(B5)	7250	37.4
	40	33.82	41	6575	30	1.1	TC-TF	7300	33.3
	50	47.93	29	6833	22	1.1	225	7400	23.8
	63	54.13	26	6489	18.5	1.1	(B5)	7400	21.1
180C	50	53.11	26	6234	18.5	1.1		7240	21.0
	63	63.64	22	7280	18.5	1.0	80	7280	18.5
	80	76.85	18	7313	15	1.0	90	7420	15.2
	100	99.39	14	6936	11	1.1	100	7500	11.9
	125	122.88	11	7172	9.2	1.0	112	7500	9.6
	160	147.23	10	7005	7.5	1.1	132	7550	8.1
	200	190.41	7	6644	5.5	1.1	160	7600	6.3
	250	246.73	6	6261	4	1.2	180	7650	4.9
	315	295.63	5	7502	4	1.0	(B5)	7700	4.1
	400	382.33	4	7276	3	1.1	TC-TF	7950	3.3
225B	8	8.44	166	2461	45	3.0		7500	137.1
	10	10.13	138	2955	45	2.8	132	8300	126.4
	12.5	12.45	112	3630	45	2.5	160	9100	112.8
	16	15.93	88	4644	45	2.2	180	10000	96.9
	20	19.13	73	5577	45	1.9	200	10700	86.3
	25	23.49	60	6850	45	1.6	225	11000	72.3
	31.5	30.29	46	8832	45	1.3	(B5)	11100	56.6
40	37.09	38	10800	45	1.0	TF	10800	45.0	
200C	40	42.62	33	8110	30	1.3		10900	40.3
	50	51.18	27	9740	30	1.1	100	11000	33.9
	63	62.86	22	8772	22	1.3	112	11350	28.5
	80	76.97	18	10742	22	1.0	132	11050	22.6
	100	98.04	14	11200	18.5	1.0	160	11200	18.5
	125	120.41	12	11459	15	1.0	180	11200	15.1
	160	147.45	9	10290	11	1.1	200	11200	12.0
	200	196.87	7	11400	9.2	1.0	(B5)	11400	9.2
	250	241.79	6	11504	7.5	1.0	TC-TF	11700	7.6
315	296.07	5	10330	5.5	1.1		11850	6.3	

- Flange quadrate / *Square flanges* / Viereckige Flansche
- * Rapporti speciali / *Special ratios* / Sonderverhältnisse
- Verifica termica necessaria / *Thermal rating needed* / Thermische - Prüfung erforderlich

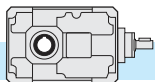

2.9 **Momenti d'inerzia** [Kg.cm²]
(riferiti all'albero veloce in entrata)

2.9 **Moments of inertia** [Kg.cm²]
(referred to input shaft)

2.9 **Trägheitsmoment** [Kg.cm²]
(bez. Antriebswelle)

TA..B - TC..B - TF..B

56B	i _n	TA	TF				
			IEC B5				
			56	63	71	80	90
8	0.25			0.32	0.40	0.60	0.77
10	0.22		0.29	0.29	0.37	0.56	0.74
12.5	0.20		0.27	0.27	0.35	0.54	0.72
16	0.18		0.25	0.26	0.33	0.53	0.71
20	0.08		0.15	0.15	0.22	0.42	0.60
25	0.07		0.14	0.15	0.22	0.42	0.59
31.5	0.07		0.14	0.14	0.21	0.41	0.59
40	0.04		0.11	0.12	0.19	0.39	0.56
50	0.04		0.11	0.11	0.19	0.39	0.56

63B	i _n	TA	TF				
			IEC B5				
			56	63	71	80	90
8	0.40		0.47	0.47	0.55	0.74	0.92
10	0.34		0.41	0.42	0.49	0.69	0.87
12.5	0.31		0.38	0.38	0.45	0.65	0.83
16	0.16		0.23	0.24	0.31	0.51	0.68
20	0.15		0.22	0.22	0.29	0.49	0.67
25	0.14		0.21	0.21	0.29	0.48	0.66
31.5	0.13		0.20	0.21	0.28	0.48	0.65
40	0.07		0.15	0.15	0.22	0.42	0.60
50	0.07		0.14	0.15	0.22	0.42	0.60
63	0.07		0.14	0.15	0.22	0.42	0.59

71B	i _n	TA	TC				TF			
			IEC B5				IEC B5			
			63	71	80	90	63	71	80	90
10	0.95		1.00	1.14	1.52	1.57	1.20	1.22	1.89	2.96
12.5	0.89		0.94	1.08	1.46	1.51	1.14	1.16	1.83	2.90
16	0.85		0.91	1.05	1.43	1.47	1.11	1.12	1.80	2.87
20	0.38		0.43	0.57	0.94	0.99	0.63	0.65	1.32	2.39
25	0.36		0.41	0.55	0.93	0.98	0.61	0.63	1.31	2.37
31.5	0.35		0.40	0.54	0.92	0.97	0.61	0.62	1.30	2.36
40	0.34		0.39	0.53	0.91	0.96	0.60	0.61	1.29	2.35
50	0.19		0.22	0.36	0.74	0.79	0.44	0.46	1.14	2.20
63	0.19		0.22	0.36	0.74	0.79	0.44	0.46	1.14	2.20
80	0.19		0.22	0.36	0.74	0.79	0.44	0.46	1.13	2.20

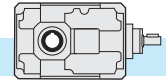







2.9 **Momenti d'inerzia** [Kg.cm²]
(riferiti all'albero veloce in entrata)



2.9 **Moments of inertia** [Kg.cm²]
(referred to input shaft)

2.9 **Trägheitsmoment** [Kg.cm²]
(bez. Antriebswelle)

TA..B - TC..B - TF..B

90B	i _n	TA 	TC 				TF 			
			IEC B5				IEC B5			
			71	80	90	110-112	71	80	90	110-112
5*	4.36	4.77	4.94	5.31	6.15	5.22	5.35	6.53	8.70	
6.3*	3.67	4.07	4.24	4.62	5.46	4.52	4.66	5.84	8.00	
10	2.77	3.18	3.35	3.73	4.57	3.63	3.77	4.94	7.11	
12.5	2.60	3.01	3.18	3.56	4.40	3.46	3.60	4.77	6.94	
16	2.49	2.90	3.07	3.44	4.28	3.35	3.48	4.66	6.82	
20	1.16	1.53	1.70	2.08	2.92	2.02	2.16	3.33	5.50	
25	1.12	1.49	1.66	2.04	2.88	1.98	2.11	3.29	5.45	
31.5	1.09	1.46	1.63	2.00	2.84	1.94	2.08	3.25	5.42	
40	1.06	1.43	1.60	1.98	2.82	1.92	2.05	3.23	5.40	
50	0.65	0.98	1.15	1.53	2.37	1.50	1.64	2.81	4.98	
63	0.64	0.97	1.14	1.52	2.36	1.50	1.63	2.81	4.97	
80	0.63	0.97	1.14	1.51	2.35	1.49	1.62	2.80	4.97	

112B	i _n	TA 	TC 				TF 			
			IEC B5				IEC B5			
			80	90	110-112	132	80	90	110-112	132
5*	12.20	13.70	13.57	14.53	17.67	14.53	14.46	16.78	30.77	
10	8.51	9.44	9.31	10.26	13.40	10.84	10.77	13.09	27.08	
12.5	7.67	8.60	8.47	9.42	12.56	10.00	9.93	12.25	26.24	
16	7.27	8.20	8.07	9.03	12.16	9.61	9.54	11.85	25.85	
20	3.62	4.46	4.33	5.29	8.43	5.96	5.89	8.20	22.20	
25	3.39	4.23	4.10	5.06	8.20	5.73	5.66	7.97	21.97	
31.5	3.29	4.13	4.00	4.95	8.09	5.62	5.55	7.87	21.86	
40	3.21	4.05	3.92	4.87	8.01	5.55	5.47	7.79	21.79	
50	1.79	2.50	2.37	3.32	6.46	4.13	4.05	6.37	20.37	
63	1.77	2.47	2.35	3.30	6.44	4.10	4.03	6.34	20.34	
80	1.75	2.46	2.33	3.28	6.42	4.08	4.01	6.33	20.32	

140B	i _n	TA 	TC 						TF 					
			IEC B5						IEC B5					
			80	90	110-112	132	160	180	80	90	110-112	132	160	180
7*	29.65	30.78	30.65	30.79	33.99	38.41	41.43	31.85	34.23	34.40	49.26	51.44	96.71	
10	25.04	26.17	26.04	26.18	29.38	33.80	36.82	27.23	29.62	29.79	44.65	46.83	92.10	
12.5	22.28	23.41	23.28	23.42	26.62	31.05	34.06	24.48	26.86	27.04	41.90	44.08	89.34	
16	21.26	22.39	22.26	22.40	25.60	30.02	33.04	23.46	25.84	26.01	40.87	43.05	88.32	
20	9.17	10.13	10.00	10.14	13.34	17.76	20.78	11.37	13.75	13.92	28.78	30.97	76.23	
25	8.42	9.38	9.25	9.39	12.59	17.01	20.03	10.62	13.00	13.17	28.03	30.22	75.48	
31.5	8.14	9.10	8.97	9.11	12.31	16.73	19.75	10.34	12.72	12.90	27.76	29.94	75.20	
40	7.92	8.87	8.74	8.88	12.08	16.51	19.52	10.11	12.49	12.67	27.53	29.71	74.98	
50	4.28	4.94	4.81	4.95	8.15	12.57	15.59	6.47	8.85	9.03	23.89	26.07	71.34	
63	4.21	4.87	4.74	4.88	8.08	12.50	15.52	6.40	8.79	8.96	23.82	26.00	71.27	
80	4.15	4.81	4.68	4.82	8.02	12.44	15.46	6.35	8.73	8.91	23.77	25.95	71.21	

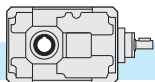

2.9 **Momenti d'inerzia** [Kg.cm²]
(riferiti all'albero veloce in entrata)

2.9 **Moments of inertia** [Kg.cm²]
(referred to input shaft)

2.9 **Trägheitsmoment** [Kg.cm²]
(bez. Antriebswelle)

TA..B - TC..B - TF..B

180B	i _n	TA	TC					TF				
			IEC B5					IEC B5				
			100-112	132	160	180	200	100-112	132	160	180	200
10	78.24	80.83	86.51	85.51	88.42	98.81	97.86	99.23	101.41	150.52	147.05	
12.5	68.84	71.43	77.11	76.11	79.02	89.41	88.46	89.82	92.01	141.12	137.65	
16	66.22	68.81	74.49	73.49	76.40	86.79	85.84	87.20	89.38	138.50	135.03	
20	28.52	31.29	36.97	35.97	38.88	49.27	48.14	49.50	51.68	100.80	97.33	
25	25.96	26.14	31.82	30.82	33.73	44.12	45.58	46.94	49.12	98.24	94.77	
31.5	25.25	28.01	33.69	32.69	35.60	45.99	44.86	46.23	48.41	97.53	94.05	
40	24.43	27.19	32.88	31.88	34.79	45.17	44.04	45.41	47.59	96.71	93.23	
50	11.97	14.25	19.93	18.93	21.84	32.23	31.59	32.95	35.13	84.25	80.78	
63	11.80	14.07	19.75	18.75	21.66	32.05	31.41	32.78	34.96	84.08	80.60	
80	11.59	13.87	19.55	18.55	21.46	31.85	31.21	32.57	34.75	83.87	80.40	

200B	i _n	TA	TC					TF					
			IEC B5					IEC B5					
			110-112	132	160	180	200	110-112	132	160	180	200	225
8	109.38	110.72	116.40	115.40	118.31	128.70	129.00	130.37	132.55	181.66	178.19	181.78	
10	95.71	97.05	102.73	101.73	104.64	115.03	115.33	116.69	118.87	167.99	164.52	168.11	
12.5	85.34	86.68	92.36	91.36	94.27	104.66	104.96	106.32	108.51	157.62	154.15	157.74	
16	79.58	80.92	86.60	85.60	88.51	98.90	99.20	100.56	102.74	151.86	148.39	151.98	
20	75.15	76.49	82.17	81.17	84.08	94.47	94.77	96.13	98.32	147.43	143.96	147.55	
25	31.37	32.88	38.56	37.56	40.47	50.86	50.98	52.35	54.53	103.65	100.17	103.76	
31.5	29.80	31.31	36.99	35.99	38.90	49.29	49.41	50.78	52.96	102.08	98.60	102.20	
40	28.59	30.11	35.79	34.79	37.70	48.09	48.21	49.57	51.75	100.87	97.40	100.99	
50	20.48	21.49	27.17	26.17	29.08	39.47	40.09	41.46	43.64	92.76	89.28	92.88	
63	20.01	21.02	26.70	25.70	28.61	39.00	39.62	40.99	43.17	92.29	88.81	92.40	

225B	i _n	TA	TF				
			IEC B5				
			132	160	150	200	225
8	265.00	337.3	345.3	343.3	339.8	342.6	
10	249.31	321.6	329.6	327.6	324.1	326.9	
12.5	234.27	306.6	314.5	312.5	309.1	311.9	
16	90.92	163.2	171.2	169.2	165.7	168.5	
20	86.52	158.8	166.8	164.8	161.3	164.1	
25	82.29	154.6	162.6	160.6	157.1	159.9	
31.5	68.32	140.6	148.6	146.6	143.1	145.9	
40	64.25	136.5	144.5	142.5	139.0	141.9	

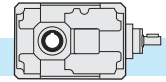





2.9 **Momenti d'inerzia** [Kg.cm²]
(riferiti all'albero veloce in entrata)



2.9 **Moments of inertia** [Kg.cm²]
(referred to input shaft)

2.9 **Trägheitsmoment** [Kg.cm²]
(bez. Antriebswelle)

TA..C - TC..C - TF..C

56C	i _n	TA 	TF 				
			IEC B5				
			56	63	71	80	90
40	0.06	0.136	0.139	0.212	0.410	0.588	
50	0.06	0.134	0.138	0.211	0.409	0.587	
63	0.06	0.134	0.137	0.210	0.408	0.586	
80	0.06	0.133	0.137	0.210	0.408	0.585	
100	0.06	0.129	0.132	0.205	0.403	0.581	
125	0.06	0.129	0.132	0.205	0.403	0.581	
160	0.06	0.128	0.132	0.205	0.403	0.581	
200	0.06	0.127	0.131	0.204	0.402	0.580	
250	0.06	0.127	0.131	0.204	0.402	0.580	

63C	i _n	TA 	TF 				
			IEC B5				
			56	63	71	80	90
40	0.07	0.142	0.145	0.218	0.416	0.594	
50	0.07	0.139	0.143	0.216	0.414	0.592	
63	0.07	0.138	0.142	0.215	0.413	0.590	
80	0.06	0.132	0.136	0.209	0.407	0.585	
100	0.06	0.132	0.135	0.208	0.406	0.584	
125	0.06	0.131	0.135	0.208	0.406	0.584	
160	0.06	0.131	0.135	0.208	0.406	0.583	
200	0.06	0.129	0.132	0.205	0.403	0.581	
250	0.06	0.129	0.132	0.205	0.403	0.581	
315	0.06	0.129	0.132	0.205	0.403	0.581	

80C	i _n	TA 	TC 				TF 			
			IEC B5				IEC B5			
			63	71	80	90	63	71	80	90
50	0.90	0.95	1.09	1.47	1.52	1.15	1.17	1.84	2.91	
63	0.86	0.91	1.05	1.43	1.48	1.11	1.13	1.81	2.87	
80	0.86	0.91	1.05	1.43	1.48	1.11	1.13	1.80	2.87	
100	0.36	0.41	0.55	0.93	0.98	0.62	0.63	1.31	2.38	
125	0.35	0.38	0.52	0.90	0.95	0.61	0.62	1.30	2.37	
160	0.35	0.40	0.54	0.92	0.97	0.61	0.62	1.30	2.36	
200	0.35	0.40	0.54	0.92	0.97	0.61	0.62	1.30	2.36	
250	0.19	0.22	0.36	0.74	0.79	0.44	0.46	1.14	2.20	
315	0.19	0.22	0.36	0.74	0.79	0.44	0.46	1.14	2.20	
400	0.19	0.22	0.36	0.74	0.79	0.44	0.46	1.14	2.20	
500	0.19	0.22	0.36	0.74	0.79	0.44	0.46	1.13	2.20	
630	0.19	0.22	0.36	0.74	0.79	0.44	0.46	1.13	2.20	

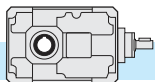

2.9 **Momenti d'inerzia** [Kg.cm²]
(riferiti all'albero veloce in entrata)

2.9 **Moments of inertia** [Kg.cm²]
(referred to input shaft)

2.9 **Trägheitsmoment** [Kg.cm²]
(bez. Antriebswelle)

TA..C - TC..C - TF..C

	i _n	TA	TC				TF			
			IEC B5				IEC B5			
			71	80	90	110-112	71	80	90	110-112
100C	50	2.68	3.08	3.25	3.63	4.47	3.53	3.67	4.84	7.01
	63	2.56	2.96	3.13	3.51	4.35	3.41	3.55	4.72	6.89
	80	2.53	2.94	3.11	3.49	4.33	3.39	3.52	4.70	6.87
	100	1.14	1.51	1.68	2.06	2.89	2.00	2.13	3.31	5.47
	125	1.10	1.47	1.64	2.02	2.86	1.96	2.10	3.27	5.44
	160	1.10	1.47	1.64	2.02	2.86	1.96	2.09	3.27	5.44
	200	1.10	1.47	1.64	2.01	2.85	1.95	2.09	3.26	5.43
	250	0.64	0.98	1.15	1.52	2.36	1.50	1.63	2.81	4.98
	315	0.64	0.97	1.14	1.52	2.36	1.50	1.63	2.81	4.98
	400	0.64	0.97	1.14	1.52	2.36	1.50	1.63	2.81	4.98
	500	0.63	0.97	1.14	1.51	2.35	1.49	1.62	2.80	4.97
	630	0.63	0.97	1.14	1.51	2.35	1.49	1.62	2.80	4.97

	i _n	TA	TC				TF			
			IEC B5				IEC B5			
			80	90	110-112	132	80	90	110-112	132
125C	50	7.82	8.75	8.62	9.57	12.71	10.16	10.08	12.40	26.40
	63	7.46	8.39	8.26	9.22	12.36	9.80	9.73	12.04	26.04
	80	7.39	8.32	8.19	9.14	12.28	9.72	9.65	11.97	25.96
	100	3.44	4.28	4.15	5.10	8.24	5.77	5.70	8.02	22.01
	125	3.34	4.18	4.05	5.00	8.14	5.67	5.60	7.92	21.91
	160	3.32	4.16	4.03	4.98	8.12	5.65	5.58	7.90	21.89
	200	3.31	4.15	4.02	4.97	8.11	5.65	5.57	7.89	21.89
	250	1.78	2.49	2.36	3.31	6.45	4.11	4.04	6.36	20.35
	315	1.77	2.48	2.35	3.31	6.45	4.11	4.04	6.35	20.35
	400	1.77	2.48	2.35	3.30	6.44	4.11	4.03	6.35	20.35
	500	1.75	2.46	2.33	3.28	6.42	4.08	4.01	6.33	20.32
	630	1.75	2.46	2.33	3.28	6.42	4.08	4.01	6.33	20.32

	i _n	TA	TC						TF					
			IEC B5						IEC B5					
			80	90	110-112	132	160	180	80	90	110-112	132	160	180
160C	50	23.13	24.26	24.13	24.27	27.47	31.89	34.91	25.33	27.71	27.88	42.74	44.92	90.19
	63	22.01	23.14	23.01	23.15	26.35	30.77	33.79	24.21	26.59	26.77	41.63	43.81	89.07
	80	21.76	22.89	22.76	22.90	26.10	30.52	33.54	23.96	26.34	26.51	41.37	43.56	88.82
	100	8.65	9.61	9.48	9.62	12.82	17.24	20.26	10.85	13.23	13.40	28.26	30.45	75.71
	125	8.35	9.30	9.17	9.31	12.51	16.94	19.95	10.54	12.92	13.10	27.96	30.14	75.41
	160	8.28	9.23	9.10	9.24	12.44	16.87	19.88	10.47	12.86	13.03	27.89	30.07	75.34
	200	8.26	9.21	9.09	9.22	12.42	16.85	19.87	10.46	12.84	13.01	27.87	30.05	75.32
	250	4.26	4.92	4.79	4.93	8.13	12.55	15.57	6.46	8.84	9.01	23.87	26.05	71.32
	315	4.24	4.90	4.77	4.91	8.11	12.53	15.55	6.44	8.82	9.00	23.86	26.04	71.30
	400	4.24	4.90	4.77	4.91	8.11	12.53	15.55	6.43	8.81	8.99	23.85	26.03	71.30
	500	4.17	4.83	4.70	4.84	8.03	12.46	15.48	6.36	8.74	8.92	23.78	25.96	71.23
	630	4.16	4.82	4.69	4.83	8.03	12.45	15.47	6.36	8.74	8.92	23.78	25.96	71.22

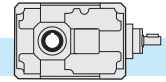







2.9 **Momenti d'inerzia** [Kg.cm²]
(riferiti all'albero veloce in entrata)

2.9 **Moments of inertia** [Kg.cm²]
(referred to input shaft)

2.9 **Trägheitsmoment** [Kg.cm²]
(bez. Antriebswelle)

TA..C - TC..C - TF..C

180C	i _n	TA 	TC 						TF 					
			IEC B5						IEC B5					
			80	90	110-112	132	160	180	80	90	110-112	132	160	180
50	23.76	24.89	24.76	24.90	28.10	32.52	35.54	25.95	28.34	28.51	43.37	45.55	90.82	
63	22.45	23.58	23.45	23.59	26.79	31.21	34.23	24.65	27.03	27.20	42.06	44.25	89.51	
80	22.17	23.30	23.17	23.31	26.51	30.93	33.95	24.37	26.75	26.93	41.79	43.97	89.23	
100	20.94	22.07	21.94	22.07	25.27	29.70	32.72	23.13	25.51	25.69	40.55	42.73	88.00	
125	8.71	9.67	9.54	9.68	12.88	17.30	20.32	10.91	13.29	13.47	28.33	30.51	75.77	
160	8.39	9.35	9.22	9.36	12.56	16.98	20.00	10.59	12.97	13.14	28.00	30.18	75.45	
200	8.05	9.01	8.88	9.02	12.22	16.64	19.66	10.25	12.63	12.81	27.67	29.85	75.11	
250	4.35	5.01	4.88	5.02	8.22	12.64	15.66	6.55	8.93	9.10	23.96	26.14	71.41	
315	4.27	4.93	4.80	4.94	8.14	12.56	15.58	6.47	8.85	9.02	23.88	26.06	71.33	
400	4.18	4.84	4.72	4.85	8.05	12.48	15.50	6.38	8.76	8.94	23.80	25.98	71.25	

200C	i _n	TA 	TC 					TF 				
			IEC B5					IEC B5				
			110-112	132	160	180	200	110-112	132	160	180	200
40	72.31	74.90	80.58	79.58	82.49	92.88	91.93	93.29	95.47	144.59	141.12	
50	71.70	74.28	79.97	78.97	81.87	92.26	91.31	92.68	94.86	143.98	140.50	
63	71.11	73.69	79.38	78.38	81.28	91.67	90.72	92.09	94.27	143.39	139.91	
80	70.63	73.22	78.90	77.90	80.81	91.20	90.24	91.61	93.79	142.91	139.43	
100	26.74	29.50	35.19	34.19	37.09	47.48	46.35	47.72	49.90	99.02	95.54	
125	26.58	29.34	35.03	34.02	36.93	47.32	46.19	47.56	49.74	98.86	95.38	
160	26.45	29.21	34.90	33.89	36.80	47.19	46.06	47.43	49.61	98.73	95.25	
200	12.17	14.44	20.12	19.12	22.03	32.42	31.78	33.15	35.33	84.45	80.97	
250	12.13	14.40	20.09	19.08	21.99	32.38	31.74	33.11	35.29	84.41	80.93	
315	12.09	14.37	20.05	19.05	21.96	32.35	31.71	33.07	35.25	84.37	80.90	

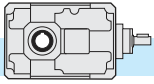

2.10 Dimensioni

2.10 Dimensions

2.10 Abmessungen

	TA...- TF...				
	56B		63B		
R	73.5		75		
F	9		9		
e	45		50		
H h8	65		70		
X h8	65		80		
E h8	65		70		
M	M8 x 12		M8 x 14		
C f8	70		80		
K	85		100		
L	59		65		
S	71		85		
f	9		9		
m	45		55		
c	73.5		80		
N2	6	8	8	8	8
M2	22.8	28.3	28.3	31.3	33.3
D2 H7	20	25	25	28	30
b	73.5		75		
r	45		50		
B	92		111		
G	90		100		
V	97		117		
C2	100		120		
F2	9		9		
N1	4		4		
M1	13.8		13.8		
D1h6	12		12		
d ₁	M4x10		M4x10		
L1	17.5		17.5		
h	113		120.2		
T	—		—		
	TA.. - TF..				
kg	4.5		6.0		

	TA...- TF...				
	56B		63B		
	73.5		75		
	9		9		
	45		50		
	65		70		
	65		80		
	65		70		
	M8 x 12		M8 x 14		
	70		80		
	85		100		
	94		100		
	36		50		
	9		9		
	45		55		
	73.5		80		
	6	8	8	8	8
	22.8	28.3	28.3	31.3	33.3
	20	25	25	28	30
	73.5		75		
	45		50		
	92		111		
	90		100		
	97		117		
	100		120		
	9		9		
	4		4		
	13.8		13.8		
	12		12		
	M4x10		M4x10		
	17.5		17.5		
	146.6		153.7		
	229		241.2		
	TA.. - TF..				
	5.0		6.5		

	TF...																			
	56B					56C					63B					63C				
IEC..B5	56	63	71	80	90	56	63	71	80	90	56	63	71	80	90	56	63	71	80	90
Y	120	140	160	200	200	120	140	160	200	200	120	140	160	200	200	120	140	160	200	200
P	153	156	163	183	183	187	190	197	217	217	160	163	170	190	190	194	197	201	221	221
Q	218	221	228	248	248	252	255	262	282	282	230	233	240	260	260	264	267	271	291	291
kg	4.5	4.5	4.5	4.5	4.5	5.0	5.0	5.0	5.0	5.0	6.0	6.0	6.0	6.0	6.0	6.5	6.5	6.5	6.5	6.5

	TF...																			
	56B					56C					63B					63C				
IEC..B14	56	63	71	80	90	56	63	71	80	90	56	63	71	80	90	56	63	71	80	90
Y	—	—	105	120	140	—	—	105	120	140	—	—	105	120	140	—	—	105	120	140
P	—	—	163	183	183	—	—	197	217	217	—	—	170	190	190	—	—	204	224	224
Q	—	—	228	248	248	—	—	262	282	282	—	—	240	260	260	—	—	274	294	294
kg	—	—	4.5	4.5	4.5	—	—	5.0	5.0	5.0	—	—	6.0	6.0	6.0	—	—	6.5	6.5	6.5

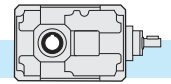

T..56B - T..56C - T..63B - T..63C

2 Riduzioni/Stages/Stufen

3 Riduzioni/Stages/Stufen

TF 56 - TF 63

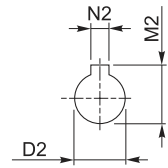
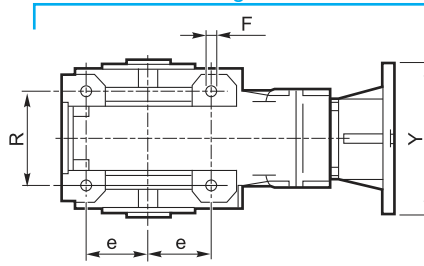
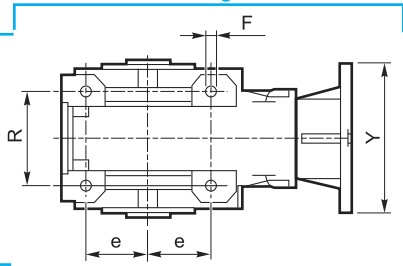

TF 56

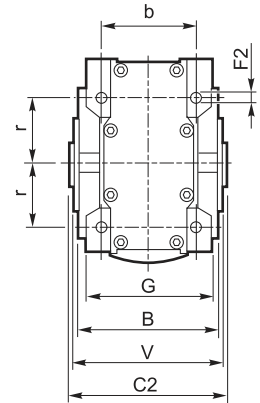
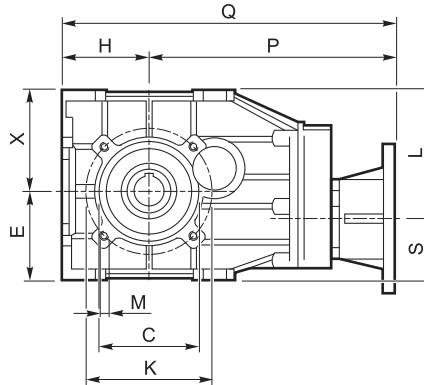
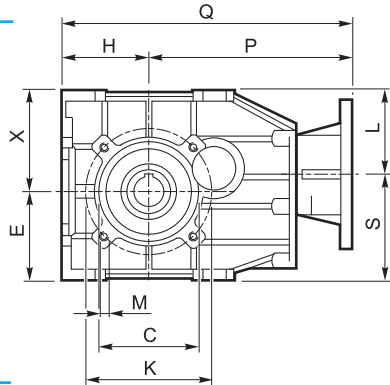

TF 63

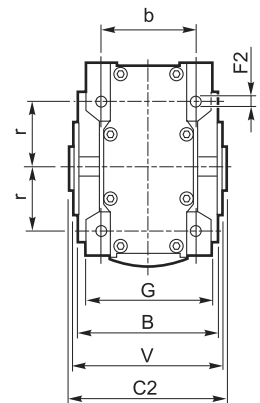
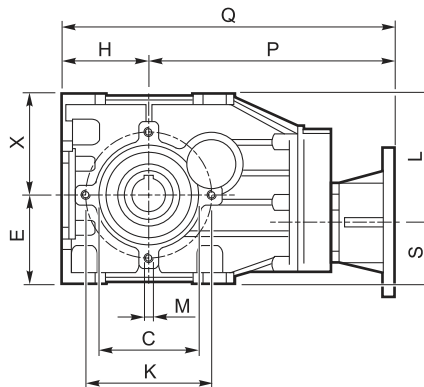
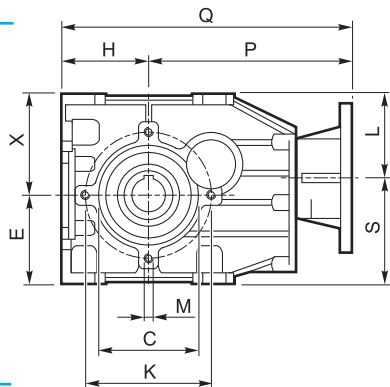

TF 56 - TF 63

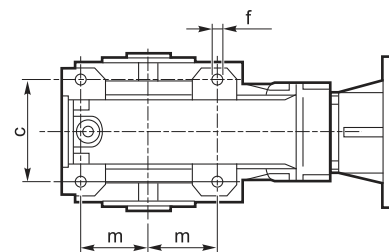
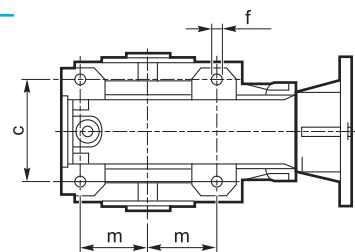

TA 56 - TA 63

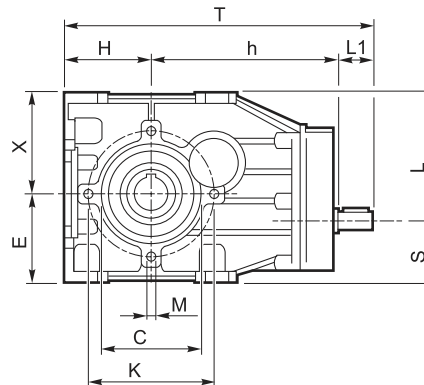
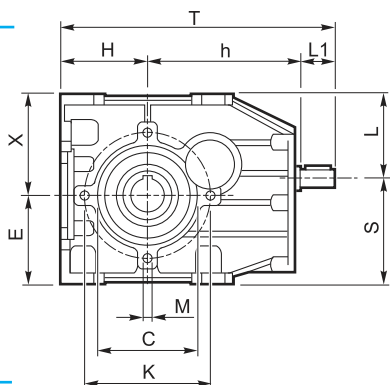

IEC	
	56 B5
	63 B5
71 B14	71 B5
	80 B5/B14
	90 B5/B14

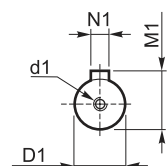

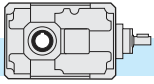

2.10 Dimensioni

2.10 Dimensions

2.10 Abmessungen

TA... - TC... - TF..																	
	71B			90B			112B			140B		180B		200B		225B	
A	142			180			224			280		360		400		450	
a	102			134			166			209		272.5		305		344	
a1	—			—			—			—		—		—		—	
B	112			127			150			175		215		255		290	
b	90			104			125			145		180		210		240	
C2	115			130			155			180		220		260		300	
D1 h6	14			19			24			28		38		38		48	
D2 H7	24	28	30	32	30	35	42	40	45	55	50	70	60	90	80	100	
E	206			262			326			407		522.5		585		654	
e	38			52			64			82		110		120		140	
F	9			11			13			15		17		19		21	
f	M8x13			M10x16			M12x19			M14x22		M16x25		M18x35		M18x30	
G	122			155			194			244		320		350		400	
g	61			77.5			97			122		160		175		200	
H	71			90			112			140		180		200		225	
h	174			212			262			317		400		422.5		500	
I	110			130			160			190		237.5		237.5		296	
i	125			159.5			199			249		322.5		360		404	
L1	30			40			50			60		80		80		110	
O	64			82			102			127		162.5		185		204	
T	275			342			424			517		660		702.5		835	
t	211			260			322			390		497.5		517.5		631	
Z	9			11			13			16		20		22		25	

TA..														
kg	12.5		20		34		58		116		165		232	

TC... - TF...														
kg	15.5		25		44		75		136		185		270	

TC...												
	71B				90B				112B			
IEC	63 B5	71 B5	80/90 B5	80 B14	71 B5	80/90 B5	*90 B14	100/112 B5	80/90 B5	100/112 B5	132 B5	
Y	140	160	200	120	160	200	□ 120 / R73	250	200	250	300	
P	177	184	204	204	220	240	240	250	286	296	318	
p	113	120	140	140	138	158	158	168	184	194	216	
Q	248	255	275	275	310	330	330	340	398	408	430	
q	184	191	211	211	228	248	248	258	296	306	328	

	140B				180B				200B					
IEC	80/90 B5	100/112 B5	132 B5	160/180 B5	100/112 B5		132 B5	160/180 B5	200 B5	100/112 B5		132 B5	160/180 B5	200 B5
Y	200	250	300	350	250		300	350	400	250		300	350	400
P	331	341	363	393	413(i=10-40) / 423(i=50-80)		463(i=10-40) / 473(i=50-80)		400	435(i=8-40) / 445(i=50-63)		485(i=8-40) / 495(i=50-63)		
p	204	214	236	266	250(i=10-40) / 260(i=50-80)		300(i=10-40) / 310(i=50-80)		400	250(i=8-40) / 260(i=50-63)		300(i=8-40) / 310(i=50-63)		
Q	471	481	503	533	593 (i=10-40) / 603(i=50-80)		643(i=10-40) / 653(i=50-80)		400	640(i=8-40) / 650(i=50-63)		690(i=8-40) / 700(i=50-63)		
q	344	354	376	406	430(i=10-40) / 440 (i=50-80)		480(i=10-40) / 490(i=50-80)		400	450(i=8-40) / 460(i=50-63)		500(i=8-40) / 510(i=50-63)		

* Flange quadrate / Square flanges / Viereckige Flansche

TF...													
	71B			90B			112B			140B			
IEC	63 B5	71 B5	80/90 B5	71 B5	80/90 B5	100/112 B5	80/90 B5	100/112 B5	132 B5	80/90 B5	100/112 B5	132 B5	160/180 B5
Y	140	160	200	160	200	250	200	250	300	200	250	300	350
P	231	238	259	286	307	317	367	377	398	432	442	463	493
p	167	174	195	204	225	235	265	275	296	305	315	336	366
Q	302	309	330	376	397	407	479	489	510	572	582	603	633
q	238	245	266	294	315	325	377	387	408	445	455	476	506

	180B				200B				225B				
IEC	100/112 B5	132 B5	160/180 B5	200 B5	100/112 B5	132 B5	160/180 B5	200 B5	225 B5	132 B5	160/180 B5	200 B5	225 B5
Y	250	300	350	400	250	300	350	400	450	300	350	400	450
P	546	566	596	596	568.5	588.5	618.5	620.5	648.5	698	728	728	760
p	393.5	403	433	433	383.5	403.5	433.5	435.5	466.5	494	524	524	556
Q	736	746	776	776	768.5	788.5	818.5	820.5	848.5	923	953	953	985
q	573.5	583	613	613	583.5	603.5	633.5	635.5	663.5	774	749	749	781

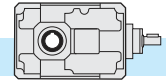

T..71B - T..225B

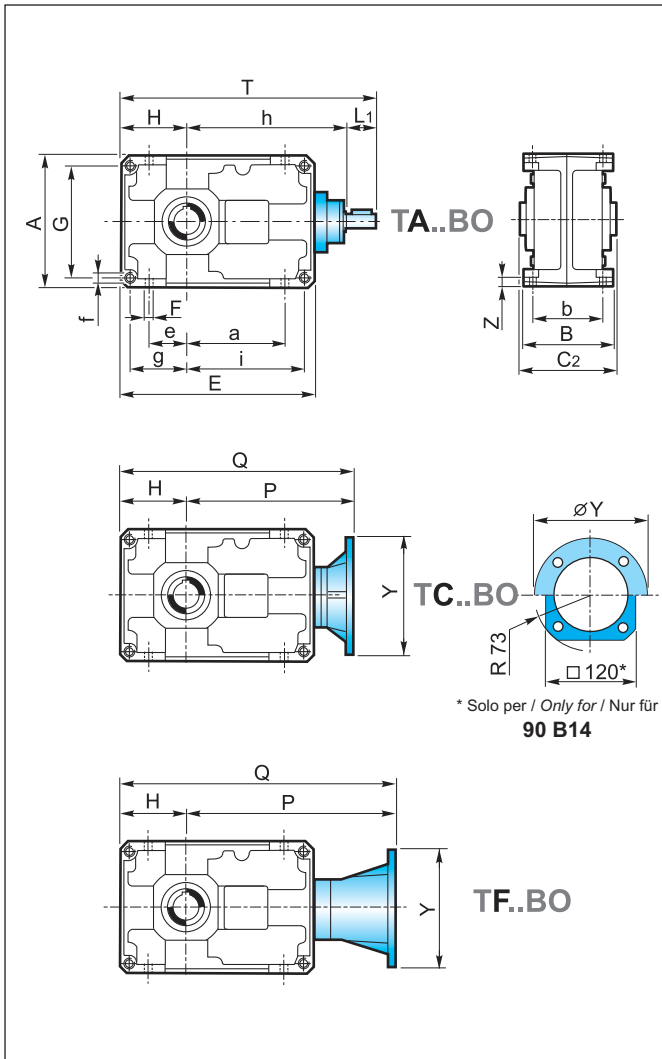

* Solo per / Only for / Nur für
90 B14

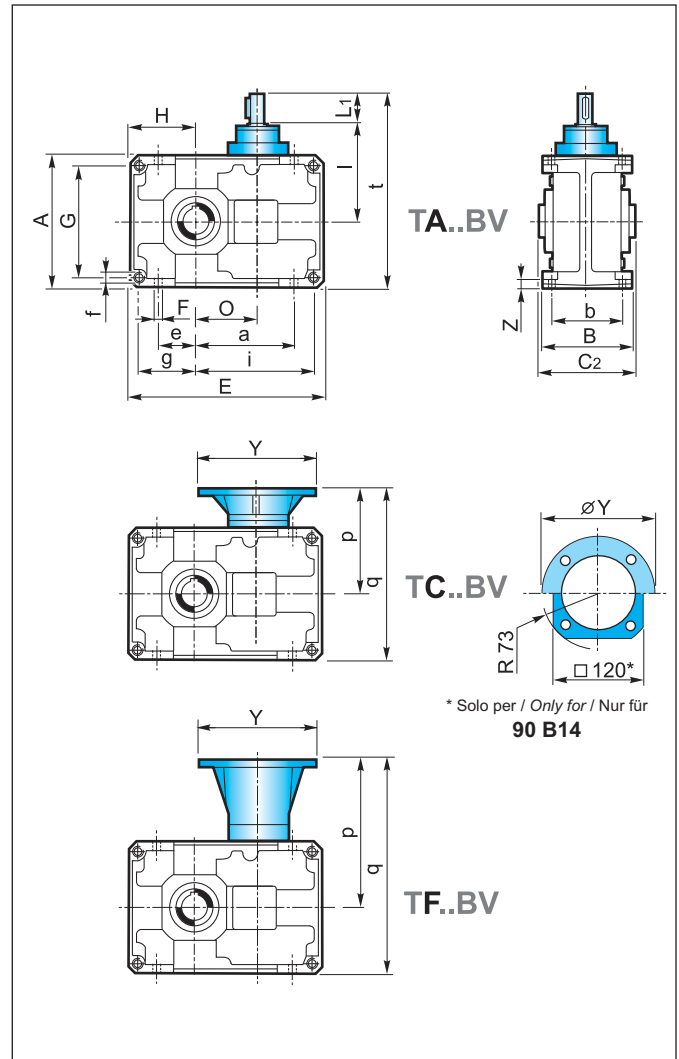

* Solo per / Only for / Nur für
90 B14

Albero uscita cavo
Hollow output shaft
Abtriebshohlwelle

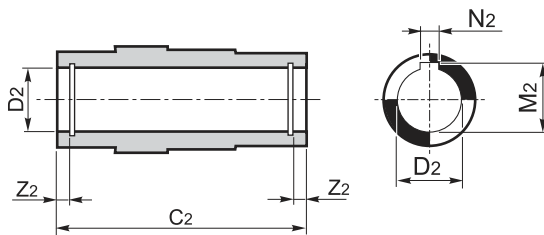

Albero entrata
Input shaft
Antriebswelle

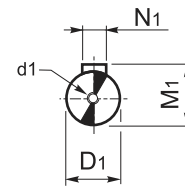

TA... - TC... - TF...

	71B		90B			112B			140B		180B		200B		225B			
D1 h6	14		19			24			28		38		38		48			
d1	M4x15		M8x22			M8x22			M8x22		M10x28		M10x28		M12x34			
M1	16		21.5			27			31		41		41		51.5			
N1	5		6			8			8		10		10		14			
C2	115		130			155			180		220		260		300			
D2 H7	24	28	30	32	30	35	42	40	45	55	50	70	60	90	80	100	90	
M2	27.3	31.3	33.3	35.3	33.3	38.3	45.3	43.3	48.8	59.3	53.8	74.9	64.4	95.4	85.4	106.4	95.4	
N2	8	8	8	10	8	10	12	12	14	16	14	20	18	25	22	28	25	
Z2	—		8.7			8.7			8.4		11		11		11		11.9	

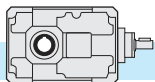

2.10 Dimensioni

2.10 Dimensions

2.10 Abmessungen

TA... - TC... - TF...													
	80C			100C			125C		160C		180C		200C
A	160			200			250		320		360		400
a	82			102			127		162.5		185		204
a1	106			134			169		217		207		277.5
B	127			150			175		215		255		290
b	104			125			145		180		210		240
C2	130			155			180		220		260		300
D1 h6	14			19			24		28		28		38
D2 H7	32	30	35	42	40	45	55	50	70	60	90	80	100
E	306			384			479		609.5		652		766.5
e	42			52			67		90		100		115
F	11			13			15		17		19		21
f	M10x16			M12x19			M14x22		M16x25		M18x35		M18x30
G	135			170			214		280		310		350
g	67.5			85			107		140		155		175
H	80			100			125		160		180		200
h	256			314			389		479.5		502		604
I	110			130			160		190		190		237.5
i	213.5			269			336		429.5		447		541.5
L1	30			40			50		60		60		80
O	146			184			229		289.5		312		366.5
T	366			454			564		699.5		742		884
t	220			270			335		410		430		517.5
Z	11			13			16		20		22		25

TA..									
kg	19		36		66		120	170	260

TC... - TF...									
kg	22		41		76		137	190	295

TC...											
	80C			100C				125C			
IEC	63 B5	71 B5	80/90 B5	80 B14	71 B5	80/90 B5	*90 B14	100/112 B5	80/90 B5	100/112 B5	132 B5
Y	140	160	200	120	160	200	□ 120 / R 73	250	200	250	300
P	259	266	286	286	322	342	342	352	413	423	445
p	113	120	140	140	138	158	158	168	184	194	216
Q	339	346	366	366	422	442	442	452	538	548	570
q	193	200	220	220	238	258	258	268	309	319	341

	160C				180C				200C				
IEC	80/90B5	100/112 B5	132 B5	160/180 B5	80/90 B5	100/112 B5	132 B5	160/180 B5	100/112 B5		132 B5	160/180 B5	200 B5
Y	200	250	300	350	200	250	300	350	250		300	350	400
P	493	503	525	555	516	526	548	578	617(i=40-160) / 627(i=200-315)		667(i=40-160) / 677(i=200-315)		
p	204	214	236	266	204	214	236	266	250(i=40-160) / 260(i=200-315)		300(i=40-160) / 310(i=200-315)		
Q	653	663	686	715	696	706	728	758	617(i=40-160) / 627(i=200-315)		867(i=40-160) / 877(i=200-315)		
q	364	374	396	426	384	394	416	446	450(i=40-160) / 460(i=200-315)		500(i=40-160) / 510(i=200-315)		

* Flange quadrate / Square flanges / Viereckige Flansche

TF...											
	80C			100C			125C				
IEC	63 B5	71 B5	80/90 B5	71 B5	80/90 B5	100/112 B5	80/90 B5	100/112 B5	132 B5	132 B5	132 B5
Y	140	160	200	160	200	250	200	250	300	300	300
P	313	320	341	388	409	419	494	504	525	525	525
p	167	174	195	204	225	235	265	275	296	296	296
Q	393	400	421	488	509	519	619	629	650	650	650
q	247	254	275	304	325	335	390	400	421	421	421

	160C				180C				200C			
IEC	80/90 B5	100/112 B5	132 B5	160/180 B5	80/90 B5	100/112 B5	132 B5	160/180 B5	100/112 B5	132 B5	160/180 B5	200 B5
Y	200	250	300	350	200	250	300	350	250	300	350	400
P	594	604	625	655	617	627	648	678	750	770	800	802
p	305	315	336	366	305	315	336	366	383.5	404	434	436
Q	754	764	785	815	797	807	828	858	950	970	1000	1002
q	465	475	496	526	485	495	516	546	583.5	604	634	636

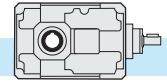

T..80C - T..200C

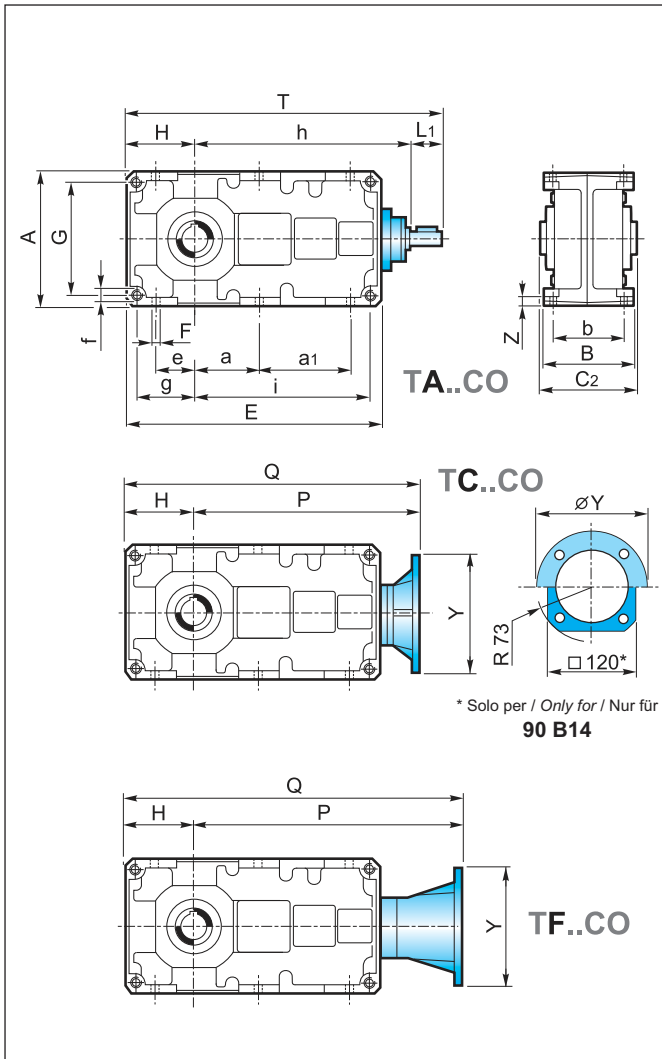

* Solo per / Only for / Nur für
90 B14

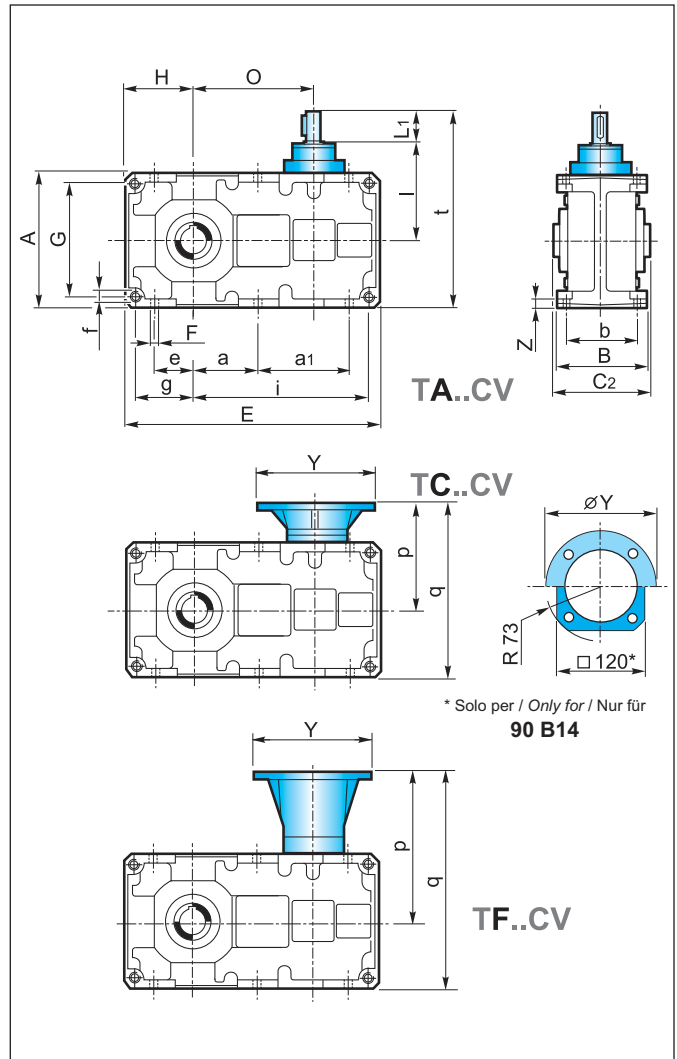

* Solo per / Only for / Nur für
90 B14

Albero uscita cavo
Hollow output shaft
Abtriebshohlwelle

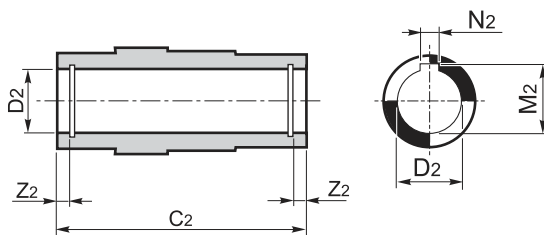

Albero entrata
Input shaft
Antriebswelle

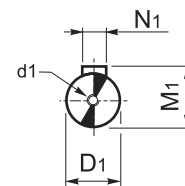

TA... - TC... - TF...

	80C		100C			125C		160C		180C		200C			
D1 h6	14		19			24		28		28		38			
d1	M4x15		M8x22			M8x22		M8x22		M8x22		M10x28			
M1	16		21.5			27		31		31		41			
N1	5		6			8		8		8		10			
C2	130		155			180		220		260		300			
D2 H7	32	30	35	42	40	45	55	50	70	60	90	80	100	90	
M2	35.3	33.3	38.3	45.3	43.3	48.8	59.3	53.8	74.9	64.4	95.4	85.4	106.4	95.4	
N2	10	8	10	12	12	14	16	14	20	18	25	22	28	25	
Z2	8.7		8.7			8.4		11		11		15.4		15.9	

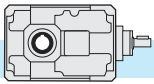

2.11 Accessori

2.11 Accessories

2.11 Zubehör

Albero lento

Output shaft

Abtriebswelle

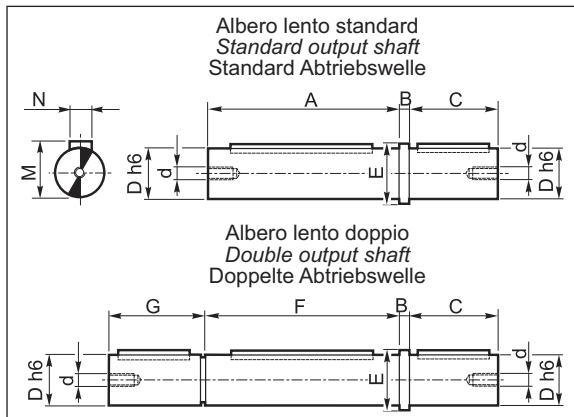

Materiale albero lento: **C45**
Output shaft material: **C45**
Material der Abtriebswelle: **C45**

	T										
	56B 56C	63B 63C	71B	90B 80C	112B 100C	140B 125C	180B 160C	200B 180C	225B 200C		
A	100	120	114	129	129	154	154	179	219	259	298
B	5	5	5	6	6	8	8	10	12	15	15
C	40	45	50	60	60	80	80	100	125	140	180
D _{h6}	20	25	24	32	35	42	45	55	70	90	100
d	M8	M8	M8	M8	M8	M10	M10	M10	M12	M16	M18
E	26	32	30	40	43	50	53	65	80	110	118
F	100	120	115	130	—	155	—	180	220	260	300
G	41	46	49	59	—	79	—	99	124	141	178
M	22.5	28	27	35	38	45	48.5	59	74.5	94	106
N	6	8	8	10	10	12	14	16	20	25	28

Albero lento cavo con calettatore

Hollow output shaft with shrink disc

Abtriebshohlwelle mit Schrumpfscheibe

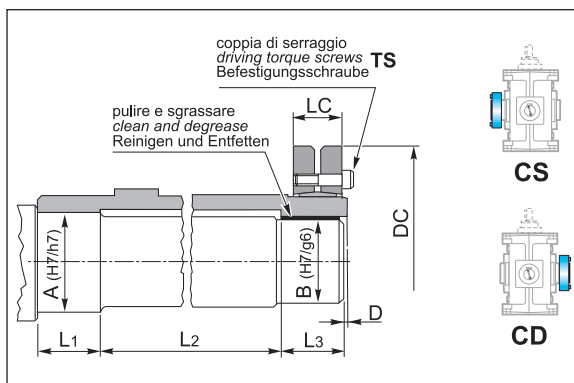

	T								
	56B 56C	63B 63C	71B	90B 80C	112B 100C	140B 125C	180B 160C	200B 180C	225B 200C
A	27	32	27	37	47	57	72	92	102
B	25	30	25	35	45	55	70	90	100
D	2	2	2	2	2	2	2	3	3
DC	60	72	60	80	100	115	155	188	215
LC	21.5	23.5	22	26	31	31	39	50	54
L ₁	32	36	36	39	45	50	60	70	80
L ₂	61	75	68	82	100	115	143	175	200
L ₃	32	36	36	39	45	50	60	70	80
TS _(Nm)	4	12	4	12	12	12	30	59	59

Kit protezione albero cavo

Hollow shaft protection kit

Schutzvorrichtung für die Hohlwelle

Ad esclusione delle grandezze 56 e 63, a richiesta è possibile predisporre il riduttore con un kit di protezione dell'albero cavo. Tale protezione, essendo dotata di un'opportuna guarnizione, impedisce ad eventuali fluidi, presenti nell'ambiente di lavoro, di venire a contatto con l'albero cavo del riduttore oltre ad impedire il contatto con corpi estranei. Le dimensioni di ingombro sono riportate nella tabella seguente.

On request we can supply a hollow shaft protection kit (except for sizes 56 and 63). The kit features a gasket which prevents any contact between hollow shaft and foreign bodies or fluids existing in the working environment. Over-all dimensions are reported in the following table.

Auf Wunsch ist eine Schutzvorrichtung für die Hohlwelle lieferbar (Größen 56 und 63 ausgenommen). Die Schutzvorrichtung weist eine Dichtung auf, die zur Vermeidung von irgendwelchem Kontakt zwischen Hohlwelle und Fremdkörper oder Flüssigkeiten der Arbeitsumgebung dient. Den Tabelle wird der Raumbedarf angegeben.

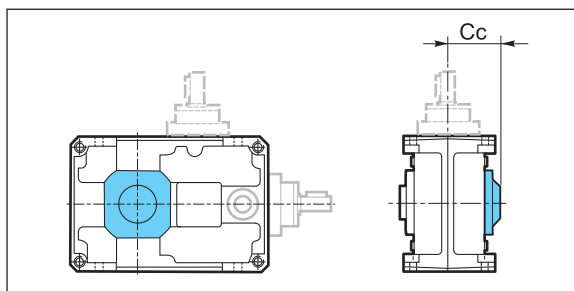

	T						
	71B	90B 80C	112B 100C	140B 125C	180B 160C	200B 180C	225B 200C
Cc	79.5	87	105	120.5	141.5	167.5	191.5

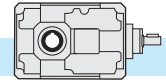
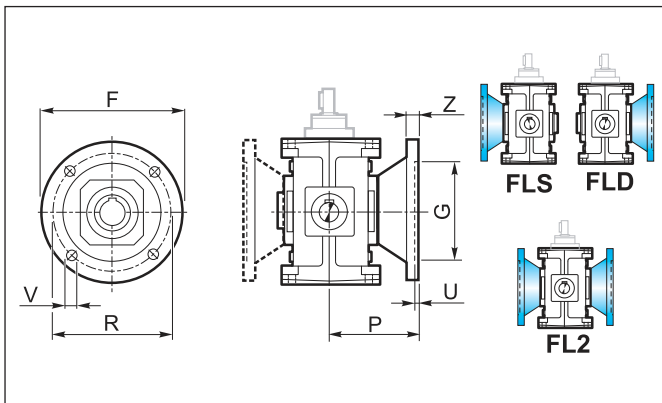

Flangia uscita
Output flange
Abtriebsflansch

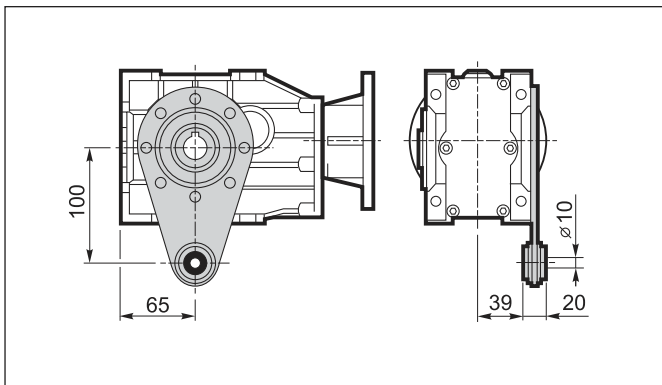
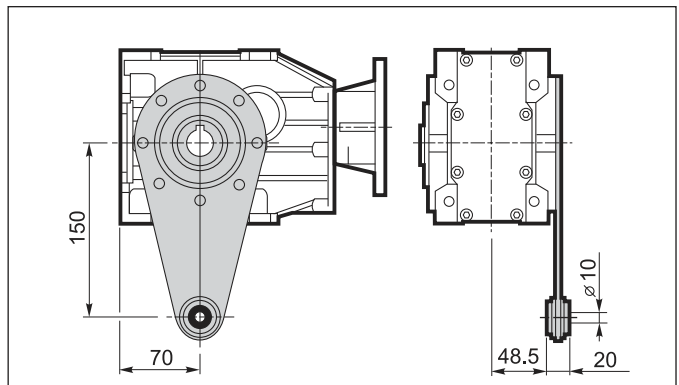
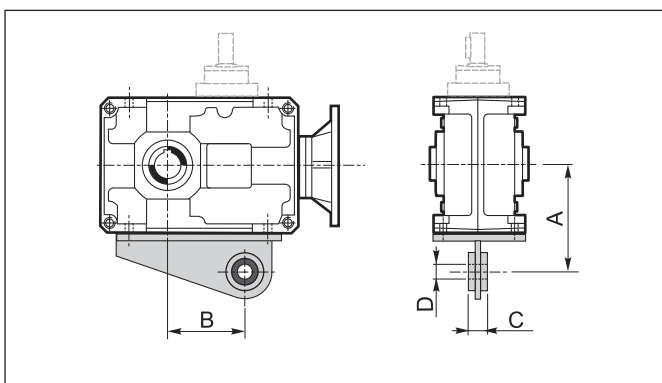
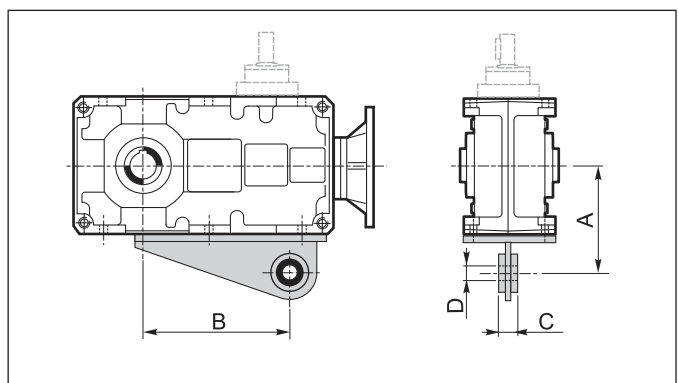
	T							
	56B 56C	63B 63C	71B	90B 80C	112B 100C	140B 125C	180B 160C	200B 180C
F	140	160	160	200	250	300	350	400
G _{G6}	95	110	110	130	180	230	250	300
R	115	130	130	165	215	265	300	350
P	82	91.5	87	100	125	150	180	215
U	5	5	4	4.5	5	5	6	6
V	9	9	12	12	14	16	18	20
Z	15	10	10	12	16	20	25	30
kg	0.5	0.5	2	3.2	5	8	12.5	24

Braccio di reazione
Torque arm
Drehmomentstütze
56B - 56C

63B - 63C

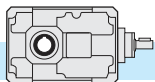
71B - 225B

80C - 200C

	T						
	71B	90B	112B	140B	180B	200B	225B
A	123	140	172	205	260	300	325
B	84	116	144	189	247.5	280	319
C	25	25	30	30	35	45	45
D	20	20	25	25	35	40	40

	T					
	80C	100C	125C	160C	180C	200C
A	130	160	190	240	280	300
B	170	214	276	354.5	367	456.5
C	25	30	30	35	45	45
D	20	25	25	35	40	40



Dispositivo antiritorno

Il riduttore ad assi ortogonali presenta valori di rendimento statico (e dinamico) molto elevati: per questo motivo non è garantita spontaneamente l'irreversibilità statica. L'irreversibilità statica si realizza quando, a riduttore fermo, l'applicazione di un carico all'albero lento non pone in rotazione l'asse entrante. Pertanto, per garantire l'irreversibilità del moto, a riduttore fermo, occorre predisporre il riduttore stesso con un opportuno dispositivo antiritorno, fornibile a richiesta tranne che sulle grandezze T56 e T63. Tale dispositivo permette la rotazione dell'albero lento solo nel senso desiderato, da specificare all'atto dell'ordine.

Backstop device

Bevel helical gearboxes feature quite high values of static (and dynamic) efficiency: for this reason spontaneous static irreversibility is not guaranteed. Static irreversibility, with motionless gearbox, occurs when the application of a load on the output shaft does not cause rotation of the input axis. In order to guarantee motion irreversibility, with motionless gearbox, it is necessary to fit a backstop device, which is available on request, except for sizes 56 and 63. The backstop device enables rotation of the output shaft only in the required direction, which is to be specified when ordering.

Rücklauf Sperre

Kegelstirnradgetriebe haben sehr hohen statischen (und dynamischen) Wirkungsgrad: deshalb wird keine spontane statische Irreversibilität garantiert. Statische Irreversibilität bei stillstehenden Getriebe hat man, wenn die Applikation mit einer Last auf die Abtriebswelle keine Drehung der Antriebswelle verursacht. Um Irreversibilität der Bewegung bei stillstehendem Getriebe zu sichern, sollte eine Rücklauf Sperre montiert werden. Die Rücklauf Sperre wird auf Wunsch geliefert (Größen 56 und 63 ausgenommen). Die Rücklauf Sperre ermöglicht, dass die Abtriebswelle nur in der gewünschten Richtung dreht (gewünschte Richtung beim Bestellen angeben).

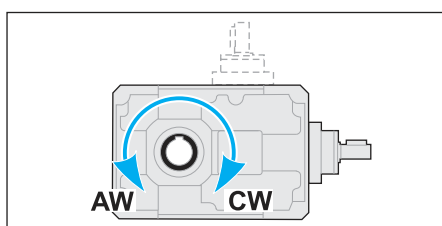

CW Rotazione oraria
Clockwise rotation
Im Uhrzeigersinn

AW Rotazione antioraria
Anti-clockwise rotation
Gegen den Uhrzeigersinn

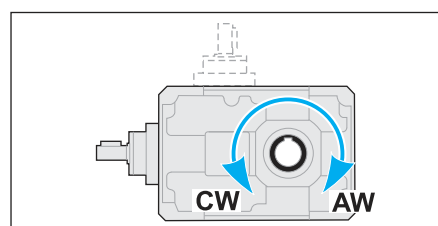

Nel caso in cui sia presente il dispositivo antiritorno è necessario l'utilizzo di olio lubrificante sintetico, classe di viscosità ISO 150.

The utilization of synthetic oil, viscosity class ISO 150, is necessary for the gearboxes equipped with back stop device.

Getriebe mit einer Rücklauf Sperre müssen mit synthetischem Oel (Viskosität ISO150) betrieben werden.

Nella tabella seguente (tab. 3) sono indicati i valori dei momenti torcenti nominali massimi (T_{2Mmax}), riferiti all'albero uscita, garantiti dal dispositivo di antiritorno, per ogni rapporto di riduzione e per ogni grandezza di riduttore. Se, in corrispondenza dell'albero lento, viene applicata una coppia maggiore di quella indicata, l'irreversibilità del moto non è più garantita. Questi valori di coppia non sono da confondere con quelli riportati nella tabella riguardante i dati tecnici dei riduttori. Infatti, si noti come in tabella siano stati messi in evidenza i valori di coppia garantiti (in uscita) dal dispositivo antiretro che risultano essere minori dei massimi valori di coppia motrice trasmissibili, con fattore di servizio $F_s = 1$, dal riduttore.

The following table (tab..3) shows the max. rated torques (T_{2Mmax}) at gearbox output guaranteed by the backstop device, for each ratio and each gearbox size. If a higher torque is applied at gearbox output, motion irreversibility is no longer guaranteed. These torque values are not to be confused with the values reported in the gearbox specifications tables. Please note that the torque values guaranteed (at output) by the backstop device are lower than the max. driving torque values transmissible by the gearbox, with service factor $F_s = 1$.

In der folgenden Tabelle (Tab. 3) werden die max. Nenn Drehmomente am Abtrieb angegeben (T_{2Mmax}), die die Rücklauf Sperre je nach Untersetzungsverhältnis und Getriebegröße garantiert. Falls am Abtrieb ein höheres Drehmoment eingesetzt wird, dann ist die Irreversibilität der Bewegung nicht mehr garantiert. Diese Drehmomente sind nicht mit den Werten zu verwechseln, die in der Tabelle der technischen Daten der Getriebe angegeben werden. Die von der Rücklauf Sperre (am Abtrieb) garantierten Drehmomente sind niedriger als die von den Getriebe übersetzbaren max. Drehmomente, unter Berücksichtigung eines Betriebsfaktors $F_s = 1$.

Vedere paragrafo 1.5 per la verifica del dispositivo antiritorno.

To check the back stop device pls see paragraph 1.5.

Überprüfung der Rücklauf Sperre siehe Abschnitt 1.5.

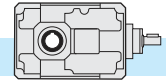

Coppia massima garantita in uscita dal dispositivo antiritorno
Max. output torque guaranteed by the backstop device
Von der Rücklaufsperrre garantierten max. Abtriebsdrehmomente

Tab. 3

T	in													
	5*	6.3*	7*	8	10	12.5	16	20	25	31.5	40	50	63	80
	T_{2M} max [Nm]													
71B	—	—	—	—	213	272	325	213	271	325	421	272	325	421
90B	148	204	—	—	333	424	508	333	424	508	657	424	508	657
112B	326	—	—	—	733	934	1118	733	933	1119	1446	933	1118	1446
140B	—	—	1038	—	1547	1969	2358	1547	1968	2359	3051	1968	2359	3050
180B	—	—	—	—	3009	3831	4588	3009	3829	4589	5935	3829	4589	5934
200B	—	—	—	5937	7607	9189	11399	12873	9190	11402	12875	11401	12875	—
225B	—	—	—	9856	11829	14538	9858	11838	14536	14537	17800	—	—	—

T	in													
	40	50	63	80	100	125	160	200	250	315	400	500	630	
	T_{2M} max [Nm]													
80C	—	1086	1301	1656	1086	1301	1656	1985	1301	1656	1985	2567	3319	
100C	—	1697	2033	2588	1697	2033	2588	3101	2033	2588	3101	4010	5186	
125C	—	3733	4474	5694	3733	4473	5693	6822	4473	5693	6822	8822	11410	
160C	—	7874	9435	12008	7873	9435	12008	14388	9434	12008	14388	18607	24064	
180C	—	7874	9435	12008	7873	9435	12008	14388	9434	12008	14388	18607	24064	
200C	12511	15024	18453	22586	15023	18450	22594	15024	18452	22594	—	—	—	

* Rapporti speciali / *Special ratios* / Sonderverhältnisse

Valori di coppia garantiti inferiori alla T_{2M}

Torque values guaranteed lower than T_{2M} value

Zuverlässige Drehmomente unter T_{2M} Wert

Dimensioni riferite alla versione con antiretro *Dimensions of the version with backstop device* Abmessungen der Version mit Rücklaufsperrre

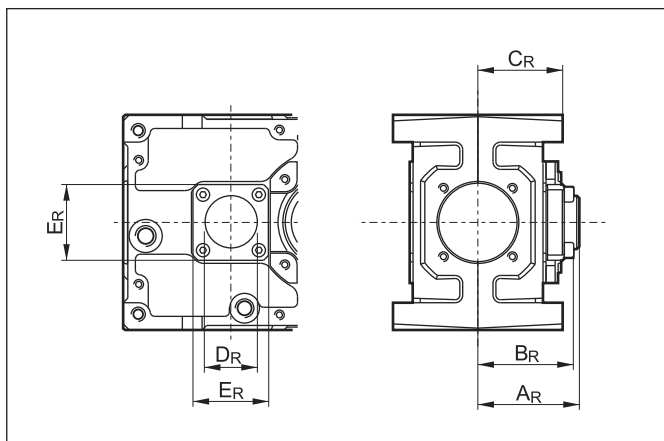

	A_R	B_R	C_R	D_R	E_R
T 71B	67	63	56	35	50
T 80C	67	63	63.5	45	60
T 90B	73	68	63.5	45	60
T 100C	71.5	70	75	55	80
T 112B	90	83	75	55	80
T 125C	86.5	96.5	87.5	60	90
T 140B	108	95	87.5	70	90
T 160C	106.5	101	107.5	70	100
T 180B	122	113	107.5	80	110
T180C	110.5	110	127.5	70	100
T200B	163	137.5	127.5	90	160
T 200C	125	124	145	90	130
T 225B	169	147	145	110	155

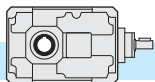

2.12 Giochi angolari

Bloccando l'albero di entrata, il gioco viene misurato sull'albero uscita ruotandolo nelle due direzioni ad applicando la coppia strettamente necessaria a creare il contatto tra i denti degli ingranaggi, al massimo pari al 2% della coppia massima garantita dal riduttore (T_{2M}).

Nella tabella seguente sono riportati i valori indicativi del gioco angolare (in minuti di angolo) per quanto riguarda il montaggio normale ed i valori ottenibili con una registrazione più precisa. Quest'ultima esecuzione è da utilizzare solo in caso di reale necessità in quanto potrebbe comportare un leggero aumento della rumorosità e rendere meno efficace l'azione dell'olio lubrificante.

2.12 Angular backlash

After having blocked the input shaft the angular backlash can be measured on the output shaft by rotating it in both directions and applying the torque which is strictly necessary to create a contact between the teeth of the gears. The applied torque should be at most 2% of the max. torque guaranteed by the gearbox. (T_{2M}). The following table reports the approximate values of the angular backlash (in minutes of arc) referred to standard mounting and the values to be obtained by a more precise adjustment. The latter solution should be adopted only in case of necessity because it may raise the noise level and lessen the action of the lubricant.

2.12 Winkelspiel

Nachdem die Antriebswelle blockiert worden ist, darf das Winkelspiel auf die Abtriebswelle bemessen werden. Dabei soll die Abtriebswelle in beiden Richtungen gedreht und ein Drehmoment ausgeübt werden, dass zur Entstehung eines Kontaktes zwischen den Zähnen genügt. Das ausgeübte Drehmoment soll höchstens 2% des max. vom Getriebe garantierten Drehmoment (T_{2M}) sein.

Die folgende Tabelle weist die Näherungswerte des Winkelspiels (in Bogenminuten) für Standardmontage und Montage mit präziser Regulierung. Die präzise Lösung darf nur im Notfall angewendet werden, weil infolgedessen der Geräuschpegel zunimmt und die Wirkung des Schmiermittels abnimmt.

	Gioco angolare / Backlash / Winkelspiel (1')	
	Montaggio normale Standard mounting Standardmontage	Montaggio con gioco ridotto Mounting with reduced backlash Montage mit reduziertem Winkelspiel
2 stadi/stages/stufig	16/20	12/15
3 stadi/stages/stufig	20/25	15/17

2.13 Lubrificazione

I riduttori ad assi ortogonali (ad esclusione dei tipi TF56 e TF63, con lubrificazione a vita) sono forniti predisposti per lubrificazione a olio e muniti dei tappi di carico, livello e scarico olio.

Si raccomanda di precisare sempre la posizione di montaggio desiderata in fase di ordine.

POMPA DI LUBRIFICAZIONE.

Una pompa per lubrificazione forzata dei cuscinetti superiori è fornita a richiesta sulle grandezze 112, 125, 140, 160, 180, 200 e 225 nella posizione di montaggio VA.

Nelle posizioni di montaggio in cui sono presenti cuscinetti posti al di sopra del livello dell'olio lubrificante è prevista l'applicazione di grasso speciale su tali cuscinetti per migliorarne la lubrificazione. E' possibile dotare gli stessi cuscinetti di un anello metallico (nylos) con la funzione di contenimento del grasso e, di conseguenza, di prolungare l'effetto nel tempo. Questa soluzione viene fornita su specifica richiesta.

2.13 Lubrication

Bevel helical gearboxes (except for TF56 and TF63 which are lubricated for life) require oil lubrication and are equipped with filler, level and drain plugs.

The mounting position should always be specified when ordering the gearbox.

OIL PUMP.

A pump for forced lubrication of the upper bearings is supplied on request for sizes 112, 125, 140, 160, 180, 200 and 225 in the VA mounting position.

Depending on the mounting position, the bearings may be lodged above the lubricant level. In this case it is necessary to apply special grease on the bearings in order to improve their lubrication. A metallic ring (nylos) can be fitted on the bearings it keeps the grease in place thus prolonging the action. It is supplied on specific request.

2.13 Schmierung

Die Kegelstirnradgetriebe sind für die Ölschmierung mit Einfüll-, Ölstand- und Ablassstopfen versehen.

Bei der Bestellung ist immer die gewünschte Montageposition anzugeben.

ÖLPUMPE.

Eine Pumpe für die Zwangsschmierung der oberen Lager kann auf Wunsch bei den Größen 112, 125, 140, 160, 180, 200 und 225 in der Montageposition VA geliefert werden.

Abhängig von der Einbaulage kann es sein, dass die Lager Über dem Ölstand liegen. In dem Fall wird Sonderfett auf die Lager geschmiert, um deren Schmierung zu verbessern. Ein metallischer Ring (nylos) für die Lager kann auf Wunsch geliefert werden: er hält das Fett fest und verlängert die Lebensdauer.

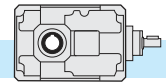

Posizione di montaggio e quantità di lubrificante (litri)

I quantitativi di olio riportati nelle varie tabelle sono indicativi e riferiti alle posizioni di lavoro indicate e considerando le condizioni di funzionamento a temperatura ambiente e velocità in ingresso di 1400 min⁻¹. Per condizioni di lavoro diverse da quelle sopra riportate contattare il servizio tecnico.

Mounting positions and lubricant quantity (liters)

The oil quantities stated in the tables are approximate values and refer to the indicated working positions, considering operating conditions at ambient temperature and an input speed of 1400 min⁻¹. Should the operating conditions be different, please contact the technical service.

Montageposition und Ölmenge (liter)

Die in der Tabellen angegebenen Daten sind Richtwerte. Die Ölmengen beziehen sich auf die angegebenen Betriebspositionen. Dabei wird den Betrieb bei Umgebungstemperatur und Antriebsdrehzahl von 1400 min⁻¹ berücksichtigt. Falls die Betriebsbedingungen anders sind, dann ist das technische Büro zu befragen.

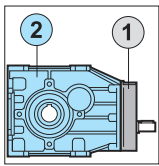
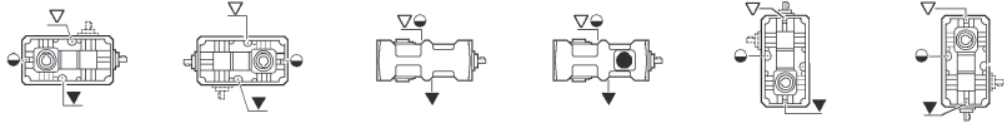

	T	B3	B8	B6	B7	VA	VB
②	56B	0.30				0.40	0.30
①	56C			0.05			
②	56C	0.30				0.40	0.30
②	63B	0.35				0.45	0.35
①	63C			0.05			
②	63C	0.35				0.45	0.35
	71B	0.6		0.7	0.5		0.8
	80C	1.1		1.5	1.3		1.5
	90B	1.0		1.4	1.2		1.3
	100C	2.0		2.6	2.3		2.8
	112B	1.8		2.6	2.3		2.4
	125C	3.8		4.8	4.5		5.0
	140B	3.6		4.6	4.3		4.3
	160C	7.0		9.2	8.7		10.0
	180B	7.5		9.7	9.2		8.0
	180C	9.5		14.0	13.0		15.5
	200B	12.5		15.0	14.0		17.5
	200C	13.5		19.0	18.0		19.5
	225B	14.5		19.0	18.0		18.7

- * Nella posizione di montaggio B6-B7 è previsto un tappo di sfiato con asta di livello.
- * In mounting position B6-B7 the breather plug is supplied complete with the dipstick.
- * Für die Version B6-B7 ist eine Entlüftungsschraube mit Ölstandsanzeige vorgesehen.

Posizione morsetti

Terminal board position

Lage des Klemmenkastens

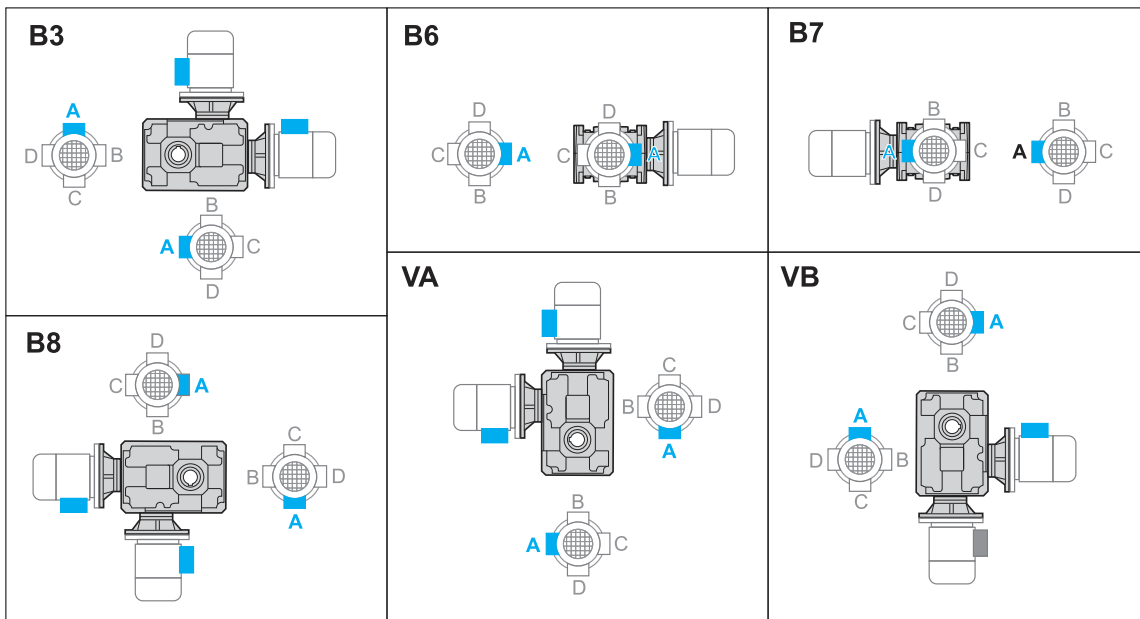

N.B. Se non diversamente specificato, il motore verrà fornito con la morsetti in posizione A.

N.B. Unless o therwise agreed, the motor will be supplied with the terminal board in position A..

ANMERKUNG: Ausser wenn anders angegeben, wird der Motor mit Klemmenkasten in der A Position geliefert.

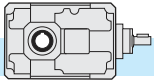

2.14 Carichi radiali e assiali (N)

Le trasmissioni effettuate tramite pignoni per catena, ruote dentate o pulegge generano delle forze radiali (F_R) sugli alberi dei riduttori. L'entità di tali forze può essere calcolata con la formula:

2.14 Radial and axial loads (N)

Transmissions implemented by means of chain pinions, wheels or pulleys generate radial forces (F_R) on the gear unit shafts. The entity of these forces may be calculated using the following formula:

2.14 Radial- und Axialbelastungen (N)

Antriebe mit Kettenritzel, Zahnrädern oder Riemscheiben erzeugen radiale Kräfte (F_R) an den Wellen der Untersetzungsgetriebe. Das Ausmaß dieser Kräfte kann nach folgender Formel berechnet werden:

$$F_R = \frac{K_R \cdot T}{d} \text{ [N]}$$

dove:

T = Momento torcente [Nm]
d = Diametro pignone o puleggia [mm]

K_R = 2000 per pignone per catena
= 2500 per ruote dentate
= 3000 per puleggia con cinghie a V

where:

T = torque [Nm]
d = pinion or pulley diameter [mm]

K_R = 2000 for chain pinion
= 2500 for wheel
= 3000 for V-belt pulley

dabei ist:

T = Drehmoment [Nm]
d = Kettenritzel- bzw. Riemscheiben
durchmesser [mm]

K_R = 2000 bei Kettenritzel
= 2500 bei Zahnrad
= 3000 bei Riemscheibe mit
Keilriemen

I valori dei carichi radiali e assiali generati dall'applicazione debbono essere sempre minori o uguali a quelli ammissibili indicati nelle tabelle.

The values of the radial and axial loads generated by the application must always be lower than or equal to the admissible values reported in the tables.

Die Werte der Radial- und Axialbelastungen, die durch die Anwendung hervorgerufen werden, dürfen nicht über den in den Tabellen angegebenen zulässigen Werten liegen.

$$F_R \geq Fr_{1-2}$$

Se il carico radiale sull'albero non è applicato a metà della sporgenza dell'albero, il valore del carico ammissibile deve essere valutato utilizzando la formula che si riferisce ad Fr_{1-2} , in cui i valori di a, b e Fr_{1-2} sono riportati nelle tabelle relative ai carichi radiali.

Nel caso di alberi bisporgenti il valore del carico applicabile a ciascuna estremità è uguale ai 2/3 del valore di tabella, purché i carichi applicati siano uguali di intensità e direzione ed agiscano nello stesso senso. Diversamente contattare il servizio tecnico.

Should the radial load affect the shaft not at the half-way point of its projection but at a different point, the value of the admissible load has to be calculated using the Fr_{1-2} formula: a, b and Fr_{1-2} values are reported in the radial load tables.

With regard to double-projecting shafts, the load applicable at each end is 2/3 of the value given in the table, on condition that the applied loads feature same intensity and direction and that they act in the same direction.

Otherwise please contact the technical department.

Falls die Radialbelastungen nicht in dem Mittelpunkt der herausragenden Welle sondern in einem anderen Punkt wirken, soll die zulässige Belastung mit der Formel bezüglich Fr_{1-2} kalkuliert werden: a, b und Fr_{1-2} Werte sind aus der Tabelle der Radialbelastungen zu entnehmen.

Bei doppelseitigen Abtriebswellen ist die Belastung, die an jedem Ende anwendbar ist, 2/3 des in der Tabelle angegebenen Wertes unter der Bedingung, dass die Belastungen die selbe Stärke und Richtung aufweisen und dass sie in der selben Richtung wirken. Andernfalls muß mit dem technischen Büro Rücksprache gehalten werden.

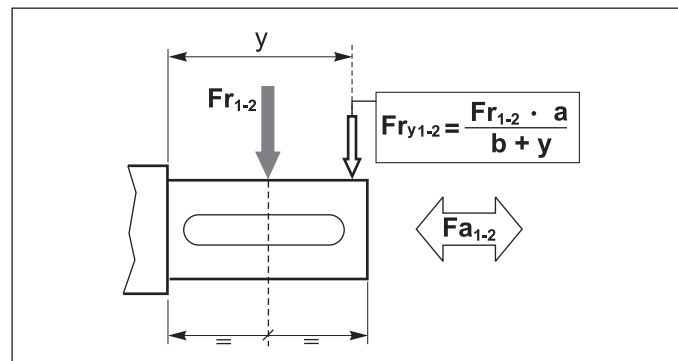

I carichi radiali indicati nelle tabelle si intendono applicati a metà della sporgenza dell'albero e sono riferiti ai riduttori operanti con fattore di servizio 1.

The radial loads indicated in the chart are considered to be applied at the half-way point of the shaft projection, and refer to gear units operating with service factor 1.

Die Radialbelastungen, die in den Tabellen angegeben werden, gelten für Ansatzpunkte in der Mitte des herausragenden Wellenteils und für Getriebe mit Betriebsfaktor 1.

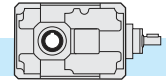

		T 56B		T 63B				T 56C		T 63C	
ALBERO ENTRATA / INPUT SHAFT / ANTRIEBSWELLE ($n_1 = 1400 \text{ min}^{-1}$)											
in		a = *	b = *	a = *	b = *	in		a = *	b = *	a = *	b = *
		Fr ₁	Fa ₁	Fr ₁	Fa ₁			Fr ₁	Fa ₁	Fr ₁	Fa ₁
Tutti All Alle		*	*	*	*	Tutti All Alle		*	*	*	*

* Consultare il ns. Servizio Tecnico.

* Contact Tramec Technical dept..

* Fragen sie Tramec technisches Büro.

		T 56B		T 63B				T 56C		T 63C	
ALBERO ENTRATA / INPUT SHAFT / ANTRIEBSWELLE ($n_1 = 1400 \text{ min}^{-1}$)											
		a = 106	b = 81	a = 121	b = 93.5	in		a = 106	b = 81	a = 121	b = 93.5
		Fr ₂	Fa ₂	Fr ₂	Fa ₂			Fr ₂	Fa ₂	Fr ₂	Fa ₂
8		1300	260	1500	300	40		2300	460	2500	500
10		1300	260	1500	300	50		2300	460	2500	500
12.5		1300	260	1500	300	63		2300	460	2500	500
16		1800	360	2000	400	80		2800	560	3000	600
20		1800	360	2000	400	100		2800	560	3000	600
25		1800	360	2000	400	125		2800	560	3000	600
31.5		1800	360	2000	400	160		2800	560	3000	600
40		2300	460	2500	500	200		3000	600	3500	700
50		2300	460	2500	500	250		3000	600	3500	700
63		—	—	2500	500	315		—	—	3500	700

		T 71B		T 90B		T 112B		T 140B		T 180B		T200B		T 225B	
ALBERO ENTRATA / INPUT SHAFT / ANTRIEBSWELLE ($n_1 = 1400 \text{ min}^{-1}$)															
in		a = 66.75	b = 51.75	a = 77	b = 57	a = 90	b = 70	a = 113	b = 83	a = 141.5	b = 101.5	a = 138.5	b = 98.5	a = 201	b = 146
		Fr ₁	Fa ₁	Fr ₁	Fa ₁	Fr ₁	Fa ₁	Fr ₁	Fa ₁	Fr ₁	Fa ₁	Fr ₁	Fa ₁	Fr ₁	Fa ₁
8-40		400	80	630	125	1000	200	1600	320	2500	500	2500	500	3150	630
50÷ 80										2000	400	2000	400		
ALBERO USCITA / OUTPUT SHAFT / ABTRIEBSWELLE ($n_1 = 1400 \text{ min}^{-1}$)															
in		a = 114.5	b = 84.5	a = 131	b = 95	a = 161.5	b = 113.5	a = 192	b = 132	a = 236.5	b = 162	a = 276	b = 191	a = 325	b = 220
		Fr ₂	Fa ₂	Fr ₂	Fa ₂	Fr ₂	Fa ₂	Fr ₂	Fa ₂	Fr ₂	Fa ₂	Fr ₂	Fa ₂	Fr ₂	Fa ₂
≤ 8		—	—	—	—	—	—	—	—	—	—	25000	5000	36000	7200
10		3000	600	4750	950	7500	1500	11800	2360	19000	3800	26800	5360	38000	7600
12.5		3150	630	5000	1000	8000	1600	12500	2500	20000	4000	28800	5760	40000	8000
16		3350	670	5300	1060	8500	1700	13200	2640	21200	4240	30400	6080	42400	8480
20		3550	710	5600	1120	9000	1800	14000	2800	22400	4480	32200	6440	44800	8960
25		3750	750	6000	1200	9500	1900	15000	3000	23600	4720	34000	6800	47200	9440
31.5		4000	800	6300	1260	10000	2000	16000	3200	25000	5000	35800	7160	50000	10000
40		4250	850	6700	1340	10600	2120	17000	3400	26500	5300	37600	7520	53000	10600

		T 80C		T 100C		T 125C		T 160C		T180C		T 200C	
ALBERO ENTRATA / INPUT SHAFT / ANTRIEBSWELLE ($n_1 = 1400 \text{ min}^{-1}$)													
in		a = 66.75	b = 51.75	a = 77	b = 57	a = 90	b = 70	a = 113	b = 83	a = 113	b = 83	a = 141.5	b = 101.5
		Fr ₁	Fa ₁	Fr ₁	Fa ₁	Fr ₁	Fa ₁	Fr ₁	Fa ₁	Fr ₁	Fa ₁	Fr ₁	Fa ₁
Tutti All Alle		400	80	630	125	1000	200	1600	320	2000	400	2500	500
ALBERO USCITA / OUTPUT SHAFT / ABTRIEBSWELLE ($n_1 = 1400 \text{ min}^{-1}$)													
in		a = 131	b = 95	a = 161.5	b = 113.5	a = 192	b = 132	a = 236.5	b = 162	a = 276	b = 191	a = 325	b = 220
		Fr ₂	Fa ₂	Fr ₂	Fa ₂	Fr ₂	Fa ₂	Fr ₂	Fa ₂	Fr ₂	Fa ₂	Fr ₂	Fa ₂
Tutti All Alle		8000	1600	12500	2500	20000	4000	32000	6400	43000	8600	53000	10600

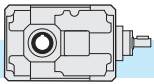

TA/TF 56B - TA/TF 63B

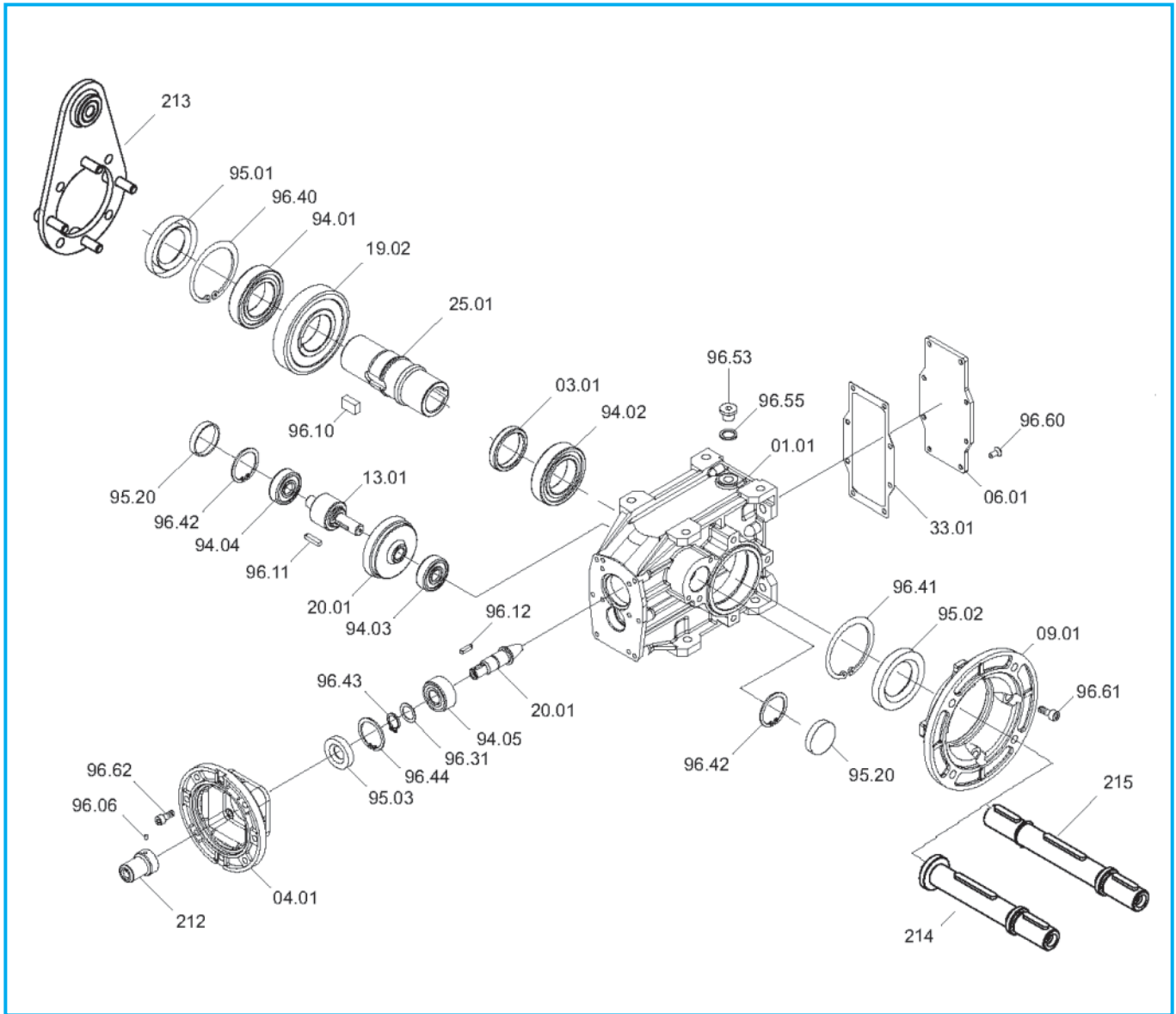

T	Cuscinetti/ Bearings / Lager					Anelli di tenuta / Oilseals / Öldichtungen		
	TA - TF					TA - TF		
	94.01	94.02	94.03	94.04	94.05	95.01	95.02	95.03
56B	6007 35/62/14	6007 35/62/14	6201 12/32/10	6201 12/32/10	3201 12/32/15.9	35/62/7	35/62/7	12/32/7
63B	6008 40/68/15	6008 40/68/15	6301 12/37/12	6301 12/37/12	3202 15/35/15.9	40/68/10	40/68/10	15/35/7

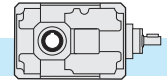

TA/TF 56C - TA/TF 63C

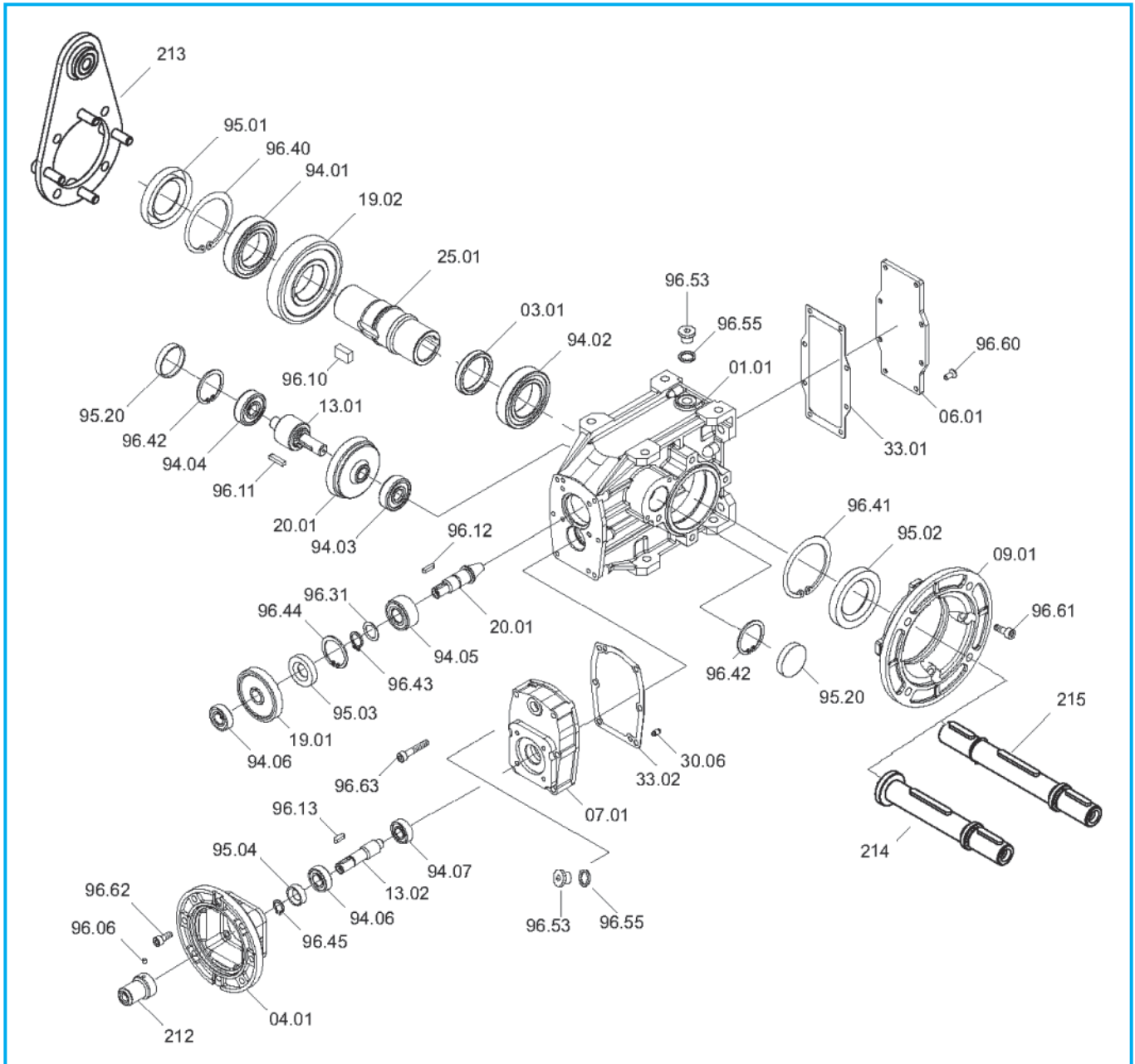

T	Cuscinetti / Bearings / Lager							Anelli di tenuta / Oilseals / Öldichtungen			
	TA - TF							TA - TF			
	94.01	94.02	94.03	94.04	94.05	94.06	94.07	95.01	95.02	95.03	95.04
56C	6007 35/62/14	6007 35/62/14	6201 12/32/10	6201 12/32/10	3201 12/32/15.9	6001 12/28/8	6000 10/26/8	35/62/7	35/62/7	12/32/7	12/22/7
63C	6008 40/68/15	6008 40/68/15	6301 12/37/12	6301 12/37/12	3202 15/35/15.9	6001 12/28/8	6000 10/26/8	40/68/10	40/68/10	15/35/7	12/22/7

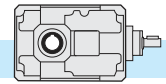

TA..C - TC..C - TF..C

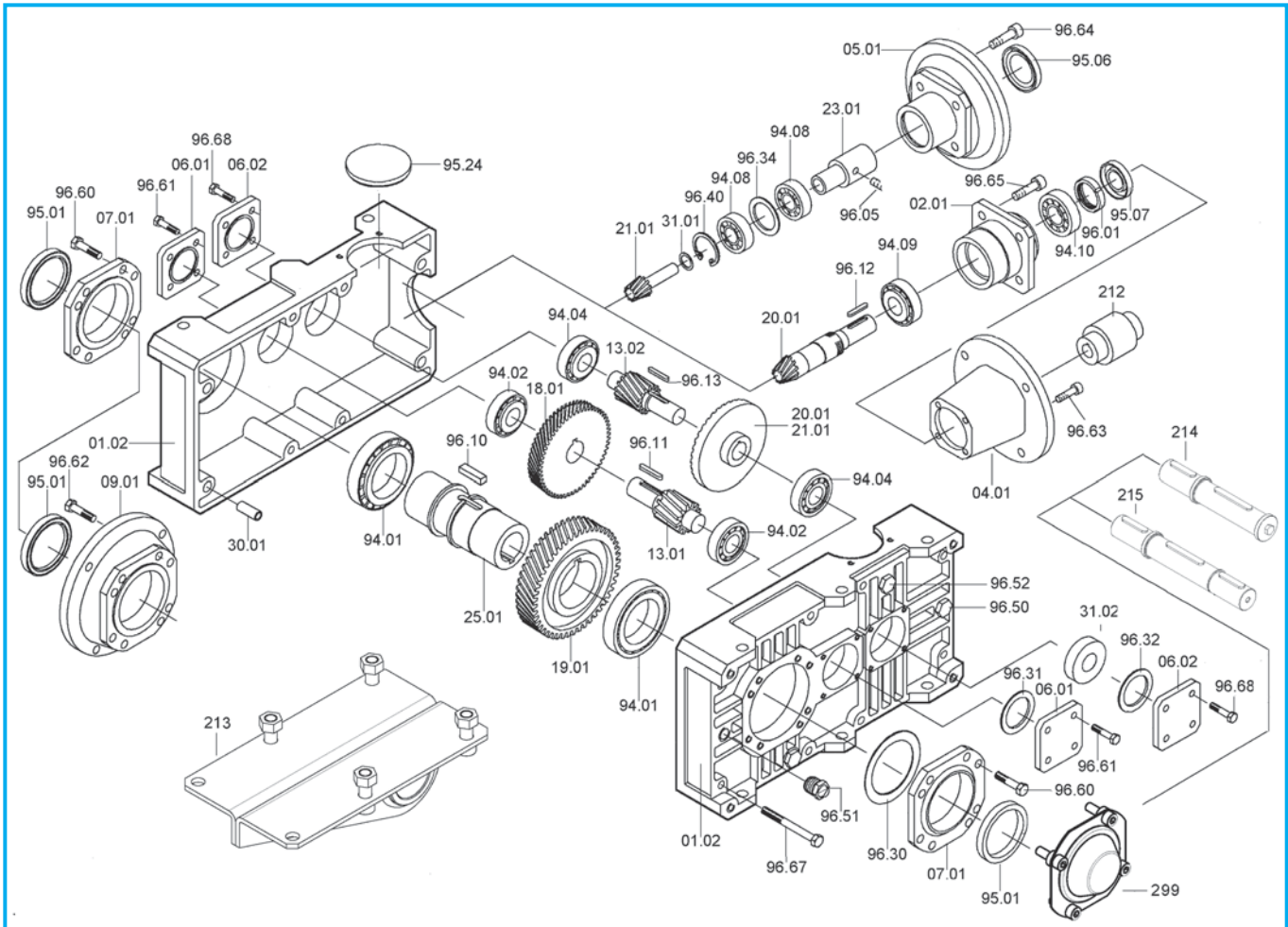

T	Cuscinetti / Bearings / Lager					Anelli di tenuta / Oilseals / Öldichtungen				
	TA - TC - TF	TC	TA - TF	TA - TC - TF	TC	TA - TF				
	94.01	94.02	94.04	94.08	94.09	94.10	95.01	IEC	95.06	95.07
80C	32010 50/80/20	30204 20/47/15.25	30302 15/42/14.25	7203 17/40/12	32023 17/40/13.25		50/65/8	63 71 80 90	25/52/7 30/52/7 35/52/7 37/52/8	15/40/10
100C	32012 60/95/23	30305 25/62/18.25	30204 20/47/15.25	7205 25/52/15	32005 25/47/15		60/80/10	71 - 80 90 100 - 112	35/62/7 40/62/7 45/62/8	20/47/7
125C	32015 75/115/25	32206 30/62/21.25	30305 25/62/18.25	7206 30/62/16	32006 30/55/17		75/95/10	80 - 90 100 - 112 132	40/72/7 45/72/8 55/72/10	25/58/10
160C	32019 95/145/32	32207 35/72/24.25	32206 30/62/21.25	7207 35/72/17	32007 35/62/18		95/125/12	80 - 90 100 - 112 132 160 180	45/80/10 45/80/10 55/80/10 60/80/8 65/80/8	30/62/7
180C	32024 120/180/38	31309 45/100/27.25	32206 30/62/21.25	7207 35/72/17	32007 35/62/18		120/160/15	80 - 90 100 - 112 132 160 180	45/80/13 45/80/10 55/80/10 60/80/10 65/80/10	30/62/7
200C	32026 130/200/45	31310 50/110/29.25	30307 35/80/22.75	7209 45/85/38	32009 45/75/20		130/160/12	100 - 112 132 - 160 180 200	55/100/13 60/100/10 65/100/10 75/100/10	40/80/10

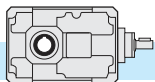

TA..B - TC..B - TF..B - TA..C - TC..C - TF..C

Dispositivo antiritorno - Backstop device - Rücklaufperre

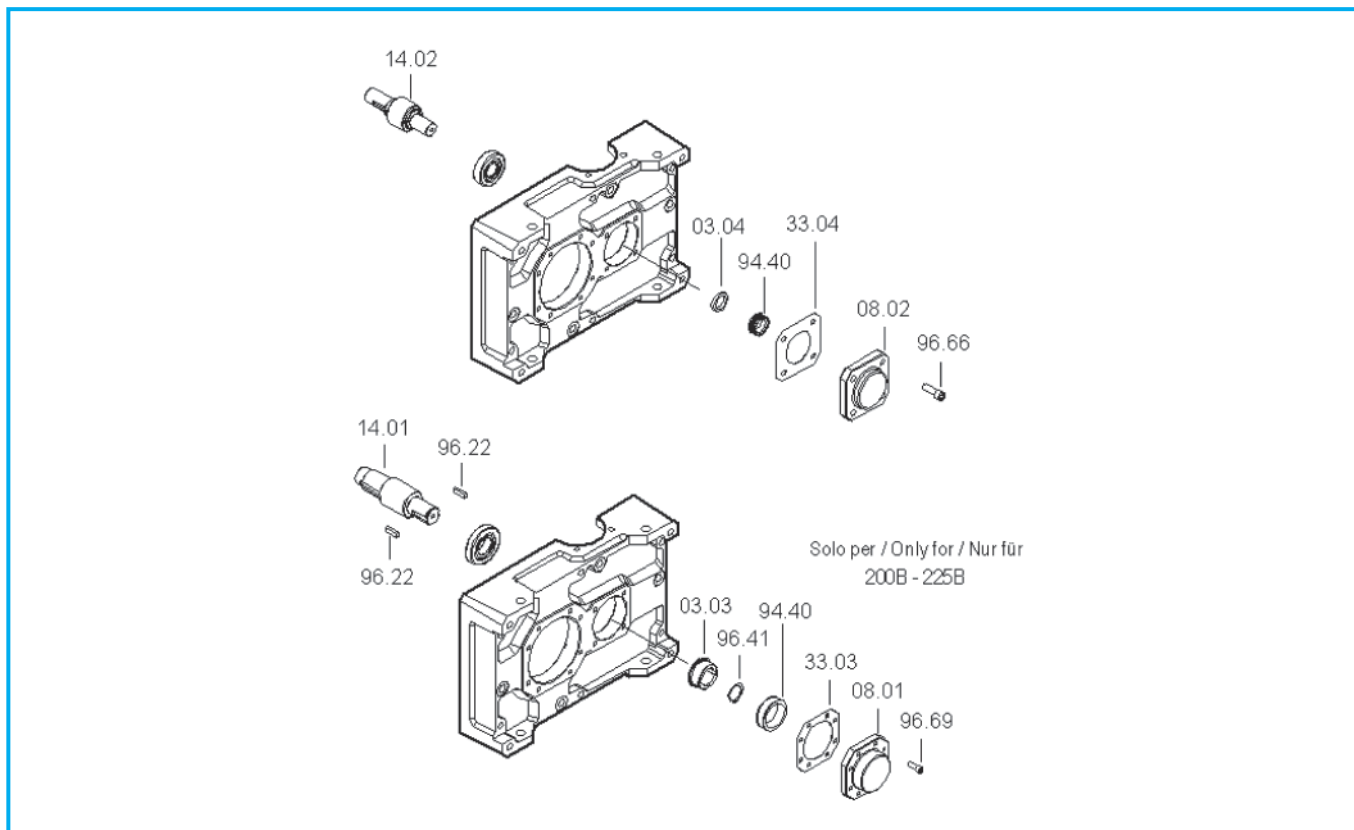

T...B	Ruota libera / Free wheel / Freilauf 94.40
71	FE 423 Z
90	FE 428 Z
112	BF 50 Z 16
140	BF 70 Z 21
180	FE 8040 Z 19
200	FE 8054 Z 25
225	FE 8072 Z 25

T...C	Ruota libera / Free wheel / Freilauf 94.40
80	FE 423 Z
100	FE 428 Z
125	BF 50 Z 16
160	BF 70 Z 21
180	BF 70 Z 21
200	FE 8040 Z 19

In fase di ordine delle parti di ricambio, specificare sempre n° particolare (vedi disegno esploso), data (1), n° codice (2) e n° variante (3). (Vedi targhetta).

When ordering please specify the spare part number (see exploded view) as well as the date (1), the article number (2) and the variant number (3) (see plate)

Bei der Bestellung von Ersatzteilen sind Ersatzteilnummer (s. Explosionszeichnung), Datum (1), Artikelnummer (2) und Variantennummer (3) anzugeben. (s. Schild)

TIPO: descrizione
TYPE: description
TYP: Bezeichnung

RAP: rapporto di riduzione
RATIO: reduction ratio
ÜBERS.: Untersetzungsverhältnis

Codice prodotto
Article code
ART.-Nr.

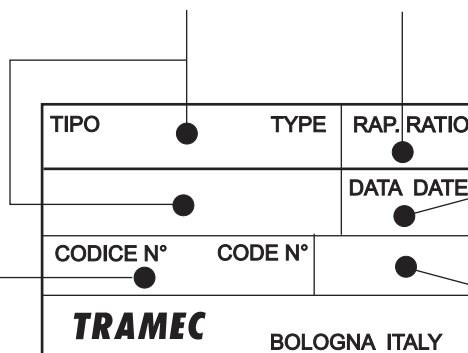

DATA: mese/anno
DATE: month/year
DATUM: Monat/Jahr

VARIANTE: codice alfanumerico
VARIANT: alphanumeric code
VARIANTE: alphanumerische Nummer